

Managing ConvexOS Operations Guide

Third Edition



CONVEX

CONVEX COMPUTER CORPORATION



CONVEX Computer Corporation
3000 Waterview Parkway
P.O. Box 833851
Richardson, TX 75083-3851
United States of America
(214)497-4000



Managing ConvexOS: Operations Guide



Order No. DSW-031

Third Edition
July 1992

CONVEX Press
Richardson, Texas
United States of America

Managing ConvexOS: Operations Guide

Order No. DSW-031

Copyright ©1992 CONVEX Computer Corporation
All rights reserved.

This document is copyrighted. This document may not, in whole or part, be copied, duplicated, reproduced, translated, electronically stored, or reduced to machine readable form without prior written consent from CONVEX Computer Corporation.

Although the material contained herein has been carefully reviewed, CONVEX Computer Corporation does not warrant it to be free of errors or omissions. CONVEX reserves the right to make corrections, updates, revisions or changes to the information contained herein. CONVEX does not warrant the material described herein to be free of patent infringement.

UNLESS PROVIDED OTHERWISE IN WRITING WITH CONVEX COMPUTER CORPORATION (CONVEX), THE PROGRAM DESCRIBED HEREIN IS PROVIDED AS IS WITHOUT WARRANTY OF ANY KIND, EITHER EXPRESSED OR IMPLIED, INCLUDING, BUT NOT LIMITED TO THE IMPLIED WARRANTIES OF MERCHANTABILITY AND FITNESS FOR A PARTICULAR PURPOSE. SOME STATES DO NOT ALLOW THE EXCLUSION OF IMPLIED WARRANTIES. THE ABOVE EXCLUSION MAY NOT BE APPLICABLE TO ALL PURCHASERS BECAUSE WARRANTY RIGHTS CAN VARY FROM STATE TO STATE. IN NO EVENT WILL CONVEX BE LIABLE TO ANYONE FOR SPECIAL, COLLATERAL, INCIDENTAL OR CONSEQUENTIAL DAMAGES, INCLUDING ANY LOST PROFITS OR LOST SAVINGS, ARISING OUT OF THE USE OR INABILITY TO USE THIS PROGRAM. CONVEX WILL NOT BE LIABLE EVEN IF IT HAS BEEN NOTIFIED OF THE POSSIBILITY OF SUCH DAMAGE BY THE PURCHASER OR ANY THIRD PARTY.

CONVEX and the CONVEX logo ("C") are registered trademarks of CONVEX Computer Corporation.

COVUE is a trademark of CONVEX Computer Corporation. COVUE products consist of COVUEbatch, COVUEbinary, COVUEedt, COVUElib, COVUEnet, and COVUEshell.

UNIX is a trademark of UNIX System Laboratories, Inc.

Printed in the United States of America

Revision information for

Managing ConvexOS: Operations Guide

Edition	Document No.	Description
Third Edition	710-011830-003	Released with ConvexOS V10.1, July 1992.
Second	710-011830-002	Released with ConvexOS V10.0, December 1991.
First	710-011830-001	March 1991. Initial release.



Contents

Using this guide	xiii
Organization	xiv
Before you begin	xvi
Notational conventions	xvii
Command syntax	xvii
General conventions	xvii
Associated documents	xix
Technical assistance.....	xx
Ordering documentation.....	xxi

1 Using the operator interface	1
The operator interface system	2
Using the op help facility	3
Invoking op tasks	4

2 Monitoring resources	5
Monitoring CPU use	6
Monitoring load averages	6
Monitoring local machine load averages	6
Monitoring remote machine load averages	7
Monitoring process status	8
Monitoring CPU activity	10
Monitoring activity since last system boot	10
Monitoring activity dynamically	12
Network I/O	14
Paging	15
CCU busy	16
Tape, Mb/s	16
Buffered I/O	16
TTY totals	17
Memory Mb	17
CPU usage	18
Path cache	18
Processes	18
Faults	19
Monitoring processes dynamically	19
Memory Mb	21
Per-CPU usage	21
Monitoring disk use	23
Monitoring free disk space	23

Monitoring used disk space	24
Monitoring current use and limits	25
Monitoring UUCP use	26
Monitoring pending UUCP activity	26
Monitoring the UUCP logfile	26
Removing old UUCP files	27
3 Controlling processes.....	29
Changing process priorities	29
Specifying nice values	30
Changing nice values	30
Scheduling processes	32
Scheduling future one-time execution	32
Scheduling multiple-time executions	34
4 Managing the line printer system	37
The line printer daemon	38
Managing printers	40
Getting help	42
Starting and stopping printer daemons	42
Restarting a printer	43
Enabling and disabling queues	43
Redirecting queues	44
Manipulating jobs in the queue	44
Scheduling downtime	45
Managing queues	46
Checking printer queues	46
Moving print jobs between queues	48
Removing print jobs from queue	49
5 Maintaining striped file systems	51
Replacing stripe partitions	52
Tracking hot spare status	53
Reclaiming hot spare status	54
6 Generating accounting reports	55
Collecting information	56
Automatic report generation	58
Manual report generation	60
Summarizing process termination data	62
By group and activity combinations	62
By command execution sequence	64
Summarizing login and logout data	66
Summarizing tape use data	68
Summarizing printer use data	70
Using the <code>pac</code> summarizing utility	71

Using general summary scripts	72
Summarizing disk use data	73
Miscellaneous utilities	75

7 Managing sendmail 77

Starting and stopping sendmail	78
Running the sendmail daemon	78
Freezing the configuration	80
Restarting sendmail with a new configuration file	81
Managing the mail queue	82
Queue priority	83
Printing the queue	84
Forcing the queue	84
Load limiting	85
Rebuilding the aliases database	87
Maintaining the log file	88
Log levels	88
Log file format	90
Debugging sendmail	91

8 Checking the file system 93

Internal view of the file system	94
The superblock	94
Summary information	94
Data blocks	94
Inodes	95
Cylinder groups	96
Fragments	97
How file system inconsistencies occur	97
File system information checked	98
Checking the superblock	98
Free block checking	98
Checking the inode state	99
Checking inode links	100
Checking inode data size	101
Checking data associated with an inode	101
Checking file system connectivity	102
Running <code>fsck</code>	103
The <code>preen</code> utility	107
Error messages	108
Initialization phase	109
Phase 1—Check blocks and sizes	113
Phase 1B—Rescan for more DUPS	116
Phase 2—Check path names	117
Phase 3—Check connectivity	122
Phase 4—Check reference counts	123
Phase 5—Check cylinder groups	127

Phase 6—Salvage cylinder groups	128
Clean-up	129
9 Performing crash dumps.....	131
Crash dump overview	132
Performing crash dumps on a variety of tape drives	133
Performing a crash dump using the default, 9-track drive	134
Performing a crash dump using a tape drive other than the default	137
Performing a crash dump using the SPU tape drive	141
What to do with crash dump tapes	144
Restarting a crash dump	145
10 Recovering from system crashes.....	147
A Line printer system error messages.....	149
lpc error messages.....	150
lpd error messages.....	151
lpmv error messages	151
lpq error messages.....	151
lpr error messages.....	153
lprm error messages	154
B Recovering from disk failure.....	155
Device failure messages	155
Disk and machine failure	156
Messages requiring operator action	156
Manual reconstruction	157
Restarting vvmdaemon.....	158
C Reporting problems	159
Prerequisites for using contact	160
UUCP connection	160
Using which to find a program's path name	160
Using vers to find a program's version number	161
Tips for using contact	162
Creating a .contact file	162
Suspending your contact session.....	162
Moving to another prompt	163
Tilde-escape sequences.....	163
Aborting your report	163
Submitting your dead.report file	164
Using contact	165
Master index	171

Figures

Figure 1	Using the which command	xvi
Figure 2	Sample <code>op -h</code> output	3
Figure 3	Sample output for <code>uptime</code> utility	6
Figure 4	Sample output for <code>ruptime</code> utility	7
Figure 5	Sample output for <code>ps</code> utility	8
Figure 6	Sample output for <code>ps -aux</code>	8
Figure 7	Sample output from <code>vmstat</code> utility	10
Figure 8	<code>syspic</code> window	13
Figure 9	<code>syspic -p proc</code> output	20
Figure 10	Sample output from <code>df</code> utility	23
Figure 11	Sample output from <code>du</code> utility	24
Figure 12	Sample output from the <code>quota</code> utility	25
Figure 13	Sample output from <code>uusnap</code> utility	26
Figure 14	Sample output from <code>uulook</code> utility	27
Figure 15	Sample <code>uclean cron</code> script	27
Figure 16	Sample output for <code>ps</code> command	31
Figure 17	Sample interactive at session	33
Figure 18	Sample <code>/usr/lib/crontab</code> file	34
Figure 19	Checking for an active <code>lpd</code> process using <code>ps</code> and <code>grep</code>	43
Figure 20	Example <code>lpq</code> output	47
Figure 21	<code>getst -H</code> output format	53
Figure 22	Input for accounting log files	56
Figure 23	Generated accounting reports	59
Figure 24	<code>awk</code> script relationship to files and summary utilities	61
Figure 25	Sample <code>sa -g</code> output	63
Figure 26	Sample <code>sabyact.awk</code> script output	63
Figure 27	Sample <code>sabygrp.awk</code> output	63
Figure 28	Sample <code>lastcomm</code> utility output	64
Figure 29	Sample <code>connecttime</code> utility output	66
Figure 30	Sample <code>connecttime.awk</code> output	67
Figure 31	Sample <code>/usr/adm/tp-acct</code> file	68
Figure 32	Sample <code>tape.awk</code> output	69
Figure 33	Sample <code>lpd_acct</code> file	70
Figure 34	Sample <code>pac</code> utility output	71
Figure 35	Sample <code>diskuse</code> utility output	73
Figure 36	Sample <code>diskbygrp.awk</code> output	74
Figure 37	Sample <code>diskbyusr.awk</code> output	74
Figure 38	Sample <code>genbygrpact.awk</code> output	75
Figure 39	Sample sorted <code>genbygrpact.awk</code> output	75

Figure 40	Sample sorted and idtoname genbygr pact .awk output	76
Figure 41	Killing the sendmail daemon	80
Figure 42	Mail queue contents	84
Figure 43	Log file entries	90
Figure 44	Inode structure	95
Figure 45	Layout of cylinder groups	96
Figure 46	Sample fsck session	105
Figure 47	Example crashdump output on start	135
Figure 48	Example crashdump comment	135
Figure 49	Example mount tape prompt	136
Figure 50	Example of successful crash dump completion	136
Figure 51	Example of initial crashdump output	138
Figure 52	Example of a crashdump comment	138
Figure 53	Example of selecting an alternate drive for crashdump	139
Figure 54	Example mount tape prompt	140
Figure 55	Example of successful crashdump completion	140
Figure 56	Example crashdump output on start	141
Figure 57	Example crashdump comment	142
Figure 58	Example mount tape prompt	142
Figure 59	Example of successful crashdump completion	143
Figure 60	Example crashdump error	145
Figure 61	Sample getst output	157

Tables

Table 1	Time interval values	78
Table 2	Recommended x and X option values	86
Table 3	sendmail log levels	88
Table 4	Tape system and SPU /ioconfig drive types	139

Using this guide

Managing ConvexOS: Operations Guide describes how to use ConvexOS utilities to monitor and control system resources such as the line printer and tape systems. This guide is intended for system managers or their appointed assistants. Many of the tasks described in this manual do not require superuser privileges.

This book does not describe the SPU or power up and power down procedures. Refer to the *CONVEX SPU System Manager's Guide* or *CONVEX C3800 SPU System Manager's Guide*, whichever was shipped to your site.

Organization

Managing ConvexOS is a multilayered task. You require two basic types of information:

- Information to plan and allocate system resources and define their limits
- Information to monitor and control day-to-day system activity and keep the system functioning within the limits you set

For example, information required to set up the line printer system is distinctly different from the information required to manage it on a daily basis.

Because of this, *Managing ConvexOS* is packaged as a two-book set:

- *Managing ConvexOS: Configuration Guide* (hereafter referred to as the *Configuration Guide*)
- *Managing ConvexOS: Operations Guide* (hereafter referred to as the *Operations Guide*)

This volume, the *Operations Guide*, contains material on monitoring, controlling, and managing system resources, such as managing the line printer system, and monitoring system resources. The system manager needs this information to maintain the system on a daily basis.

The *Configuration Guide* contains material on configuring system resources, such as setting up the disk system, customizing boot-time parameters, and setting up the line printer system. The system manager needs this information when configuring a new system or modifying the configuration of an existing system

Once you have used the *Configuration Guide* to help configure your system, you can place it on a shelf until the next time you must perform configuration tasks. All the information you need to perform daily tasks are in one volume, the *Operations Guide*.

In both books, the information is divided into tasks. For example, the *Configuration Guide* has chapters such as:

- "Setting up the disk system"
- "Setting quotas on disk space use"
- "Maintaining user accounts"

The *Operations Guide* contains chapters such as:

- "Using the operator interface"
- "Maintaining striped file systems"
- "Generating accounting reports"

When configuring the system for the first time, there is a logical order in which tasks should be performed, as some tasks require information to be in place before they can be performed. For example, users must be in the system before you can establish disk use quotas for them. Chapters in the *Configuration Guide* reflect this order, although this is not rigid in all cases.

Chapters in the *Operations Guide* are not in a specific order, because it is difficult to predict the order in which daily tasks will be performed.

The information in each chapter is also presented in the order in which it is needed. Before you can perform some of the tasks, you must plan the use of the resources being configured, and before you can plan the use of system resources, you must understand certain concepts. When this is the case, the information in each chapter is presented in the following order:

- Concepts
- Planning
- Performing

The index in this guide is a master index that covers the following books:

- *ConvexOS Tape System Manager's Guide*
- *ConvexOS Tape System Operator's Guide*
- *Managing ConvexOS: Configuration Guide*
- *Managing ConvexOS: Operations Guide*

Each entry in the master index is marked to indicate the book it references.

Before you begin

Full path names of commands are not given in this manual, because they change from time to time. To run commands without specifying the full path name, you must have the following directories specified in your user path:

- /bin
- /usr/bin
- /usr/local/bin
- /usr/convex
- /usr/adm
- /usr/ucb

You can use the `which` command to determine the full path name of a program or utility. Figure 1 illustrates use of the `which` command to find the full path name of the loader (`ld`) utility.

Figure 1 Using the `which` command

```
% which ld
/bin/ld
%
```

In this example, the full path name of the loader is `/bin/ld`.

If you use the C shell (`csh`), you can also use the `whence` command to find the program path name. The `whence` command works like `which`, but is faster.

For more information on the `which` command, refer to the `which(1)` man page.

Command syntax

Consider this example:

```
COMMAND input_file [...] {a | b} [output_file]
```

① ② ③ ④ ⑤

1. **COMMAND** must be typed as it appears.
2. *input_file* indicates a file name that must be supplied by the user.
3. The horizontal ellipsis in brackets indicates that additional input file names may be supplied.
4. Either a or b must be supplied.
5. [*output_file*] indicates an optional file name.

General conventions

In general, the following conventions are used in this guide:

- **Bold constant-width font** identifies user input in examples.
- *Italics*:
 - Designate user-supplied variables in a command-line example
 - Indicate document titles
- Constant-width font designates input and output, including:
 - Command names and options
 - System calls
 - Data structures and types
 - Directives, program statements, display examples, printout examples, and error messages returned
- Horizontal ellipsis (...) shows repetition of the preceding item(s).
- Vertical ellipsis shows that lines of code have been left out of an example.
- Words and abbreviations that indicate keyboard keys you press are identified in a distinctive bold type. For example, **RETURN** refers to the carriage return key. Words separated by

a hyphen indicate two keys that you must press simultaneously. For example, **CTRL-x** indicates that you must press and hold down the **CTRL** key and then press the **x** key.

- The word “enter” in a phrase such as “enter **ls**” means that you type the command and then press **RETURN**.
- References to *ConvexOS Man Pages* appear in the form adb(1), where the name of the man page is followed by its section number enclosed in parentheses.
- The backslash (\) character at the end of a command line indicates a continuation line follows.

Note

A Note highlights supplemental information.

Caution

A Caution highlights procedures or information necessary to avoid damage to equipment, software, or data.

Associated documents

Using this software may require information not specific to the tasks described in this document.

For more information on the ConvexOS operating system, you can order these books from CONVEX Computer Corporation:

- *ConvexOS dump and restore Quick Reference* (DSW-392), a quick reference for dumping and restoring file systems
- *ConvexOS Man Pages for Users* (DSW-331), *ConvexOS Man Pages for Programmers* (DSW-332), and *ConvexOS Man Pages for System Managers* (DSW-333). This set of three books is the standard reference for the ConvexOS operating system.
- *ConvexOS Primer* (DSW-133), an introduction to ConvexOS for new users
- *ConvexOS Tape System Manager's Guide* (DSW-398), a guide and reference for ConvexOS Tape System managers
- *ConvexOS Tape System Operator's Guide* (DSW-397), a guide and reference for ConvexOS Tape System operators
- *ConvexOS Tape System Quick Reference* (DSW-391), a quick reference for the ConvexOS Tape System
- *ConvexOS Tape System User's Guide* (DSW-018), a guide and reference for the ConvexOS Tape System
- *CONVEX SPU System Manager's Guide* (DSW-022), a guide for managing CONVEX SPU OS
- *CONVEX C3800 SPU System Manager's Guide* (DSW-023), which explains procedures using the SPU OS on CONVEX C3800 Series machines
- *Managing ConvexOS: Configuration Guide* (DSW-030), a guide for configuring ConvexOS

Technical assistance

Hardware, software, and documentation support can be obtained through the CONVEX Technical Assistance Center (TAC):

- From locations in the continental United States:
 - Customers call (800)952-0379
 - CONVEX employees call (800)952-4839
- From Canada, call 1(800)345-2384
- From all other locations, contact local CONVEX office.

Ordering documentation

To order the current edition of this or any other CONVEX document, send requests to:

CONVEX Computer Corporation

Customer Service

P.O. Box 833851

Richardson TX 75083-3851 USA

Include the order number or the exact title, as listed on the front cover.

Using the operator interface

1

Because superuser privileges provide access to every command and file in the system, it is not desirable to grant superuser privileges to everyone who may need to perform a maintenance task. The operator interface, commonly called `op`, allows you to grant restricted access to superuser commands without granting superuser privileges. `op` provides an operator class of access to superuser commands. This chapter describes how to use the operator interface.

The operator interface system

ConvexOS distinguishes two classes of users: ordinary users and superusers.

A superuser has privileged access to the computer system. The superuser can perform any operation and has full read, write, and execute privileges for all files, regardless of who owns them or their access permissions. Ordinary users have access only to their files and other files to which they are explicitly granted access.

With the operator interface, the system manager can establish additional classes of users. The users in these classes are granted access to a set of commands that typically require superuser privileges; they do not receive full superuser privileges. As system manager, you can restrict:

- **Who may be an operator**—You can restrict an operator class to an individual or several individual users, a group of users as defined in the `/etc/group` file, or a combination of individuals and groups.
- **What commands the operator may use**—You can restrict the specific commands executed by users in an operator class. These commands can include custom scripts or programs designed for your site.
- **What arguments the operator may pass to the command**—You can restrict the arguments that may be passed to these commands.

Each command an operator can perform is given a task name. For example, the system manager might name a task `weekly` to describe a command he or she wants performed on a weekly basis.

Besides defining what command is executed for each task, the system manager can specify arguments the operator can pass to the command. This can be either a literal or variable argument.

Literal arguments specify command arguments, such as `0Gun` for a `dump` command, or specific file systems, such as `/mnt`. Variable arguments allow an operator to enter a desired value when the task is invoked. However, the system manager can specify limitations on what values an operator can enter for variable arguments as well.

See the `op(8)` and `op.access(5)` man pages for more details. See the chapter “Granting Operator Class Privileges” in the *Configuration Guide* for setup information.

Using the op help facility

Anyone designated as an operator can use the `op help` facility to determine which tasks are available to them or to determine the arguments available for a task. If a user enters the following command

```
% /etc/op -h
```

the `op` facility lists the functions available to that user. For example, user `smith` has operator access to two tasks: `weekly` and `daily`. If user `smith` executes the `op help` facility, `op` generates the following list:

```
weekly
```

```
daily
```

User `jones` does not have operator access. If user `jones` executes the `op help` facility, `op` generates the message

```
jones is not allowed to execute any mnemonics
```

To get information on available arguments for one of these tasks, for example on a task called `weekly`, enter the following command

```
% /etc/op -h weekly
```

If the operator has access to a task that has one variable argument specified in the command syntax, and that variable can be replaced with either `/`, `/usr`, `/mnt`, or `/project`, `op` displays the following kind of information, as illustrated in Figure 2.

Figure 2 Sample `op -h` output

```
% op -h weekly
Help for mnemonic "weekly"
      op weekly <arg1>
where
      <arg1> is "/" OR "/usr" OR "/mnt" OR "/project"
```

If no limitations are specified, you can enter any valid value for the argument. Unless an argument is specified as optional, the operator must supply a corresponding value for any variable argument when they invoke the task.

Invoking `op` tasks

Anyone with operator access to any `op` task can invoke that task using the `op` command. The format of the `op` command is

```
% /etc/op task_name [arg...]
```

where

task_name is the name of the task as defined in the `op.access` file. Each task calls an executable command, utility, or script.

arg is any argument the task will accept. For information on how to determine valid values for tasks, refer to the section, "Using the `op` help facility," on page 3.

For example, to invoke a task called `weekly` that allows you to back up either `/usr`, `/mnt`, or `/project`, you can enter:

```
% /etc/op weekly /usr
```

Resource monitoring utilities provide you with information on system performance. With these utilities, you can monitor the use and performance of the CPU, disk, and UUCP software. This chapter discusses how to use these utilities.

Monitoring CPU use

Use the following utilities to monitor CPU use:

- `uptime`—Provides information on CPU load average on a local machine.
- `ruptime`—Provides information on CPU load average on remote machines (requires CONVEX Internet Services, an optional product).
- `ps`—Provides status information on currently running processes.
- `vmstat`—Provides information on CPU activity since the last system boot.
- `syspic`—Provides information dynamically on CPU activity on a local machine.

These utilities and how to use them are described in the following sections.

Monitoring load averages

The `uptime` and `ruptime` utilities monitor CPU load averages. The `uptime` utility monitors CPUs on the local machine, and the `ruptime` utility monitors CPUs on remote machines on a local subnet.

Monitoring local machine load averages

The `uptime` utility lists the following information for a local machine:

- Number of days, hours, and minutes the system has been up
- Number of users currently logged in
- Load average over the last 1, 5, and 15 minutes

Figure 3 illustrates example output when you execute the `uptime` command.

Figure 3 Sample output for `uptime` utility

```
5:12pm up 4 days, 11:27, 60 users, load average: 4.18, 4.40, 4.27
```

Load averages represent the number of jobs waiting in the run queue over the last 1, 5, and 15 minutes. This message tells you that the system has been up for 4 days, 11 hours, and 27 minutes; that 60 users are logged in; and that the load average over the last minute was 4.18, over the last 5 minutes was 4.40, and over the last 15 minutes was 4.27.

If you are not comfortable with the load averages seen using `uptime`, or if they jump drastically from one category to the next, you may want to run `syspic` to get more definitive information on system activity. (`syspic` is described in the subsection “Monitoring activity dynamically.”)

See the `uptime(1)` man page for more information.

Monitoring remote machine load averages

The `ruptime` utility lists the following information for each remote machine:

- Machine name
- Whether the machine is up or down
- Number of days, hours, and minutes each machine has been up
- Number of users logged in to each machine
- Load average over the last 1, 5, and 15 minutes

The information provided by the `ruptime` utility is the same as for the `uptime` utility. The difference is that statistics are displayed for multiple machines. Figure 4 illustrates output from the `ruptime` utility.

Figure 4 Sample output for `ruptime` utility

```
pubs      up      4+02:24, 25 users, load 1.04, 1.01, 1.01
stone     up      2+20:59,  0 users, load 0.02, 0.02, 0.02
thistle   down    9:06
```

If you are not comfortable with the load averages seen using `ruptime`, or if they jump drastically from one category to the next, you may want to run `syspic` to get more definitive information on system activity.

See the `ruptime(1)` man page for more details.

Monitoring process status

The `ps` utility provides basic information about running processes. Figure 5 illustrates default `ps` output.

Figure 5 Sample output for `ps` utility

PID	TT	STAT	TIME	COMMAND
29911	p3	I	0:00	-csh[smith]
2017	p3	R	0:00	ps

By default, the `ps` utility lists processes with the same UID as the user running `ps`. However, you can list processes according to other criteria. Some of the more commonly used options are:

- a List all processes associated with terminals.
- u Produce a list sorted by CPU utilization. Each entry contains the name of the user running the process.
- x Include processes not assigned to a terminal.

Use the `aux` options in combination to view the percentages of CPU and memory each process is using. Figure 6 illustrates output from the `ps -aux` command.

Figure 6 Sample output for `ps -aux`

USER	PID	%CPU	%MEM	SZ	RSS	TT	STAT	TIME	COMMAND
smith	25217	34.8	0.6	6412	308	p7	R	0:00	ps-aux
smith	22506	4.7	0.3	4912	160	p8	S	2:22	syspic

Each field in this output is explained below:

USER Login name of user who owns the process.

PID Identification number of the process.

%CPU Percentage of the CPU the process is using.

%MEM Percentage of memory the process is using.

SZ Virtual size of the process in 1-kbyte units.

RSS (Resident set size) Real memory size of the process in 1-kbyte units.

TT Control terminal where the process was initiated.

STAT State of the process. This can be one or more of the following letters:

V Vector processing is being used.

R Runnable process.

- T Stopped process.
 - P Process is in page wait.
 - D Process is in disk or other short term wait.
 - S An active process (sleeping for less than 20 seconds).
 - I Idle process (sleeping longer than 20 seconds).
 - Z Zombie process (trying to exit but parent process is not waiting for it).
 - W Process is swapped out.
 - P Process is partially swapped out.
 - > Process is exceeding soft limit on memory.
 - N Process priority is reduced.
 - < Process priority has been artificially raised.
- TIME** Amount of CPU time the process has used. It might be an indication of a runaway process if this time seems excessive. Talk to the user who started the process to see if the time used seems reasonable for the process running. If it is a runaway process, kill the process or have the user who owns the process kill it.
- COMMAND** Command that initiated the process.
- See the `ps(1)` man page for more details on the information that can be displayed.

Monitoring CPU activity

Both the `vmstat` and `syspic` utilities display statistics on system activity. The `vmstat` utility reports activity since the last system boot. The `syspic` utility reports current activity dynamically.

Monitoring activity since last system boot

The `vmstat` utility provides statistics to monitor system activity averaged since the last system boot, including job distribution, virtual memory load, paging and swapping activity, and disk and CPU utilization. On a multiprocessor system, the values are averaged over all CPUs. Figure 7 illustrates output from the `vmstat` utility invoked without options.

Figure 7 Sample output from `vmstat` utility

```
procs          memory                page                faults          cpu
r  b  w      avm      fre  re  at  pi  po  fr  de  sr  in  sy  cs  vs  us  sy  id
1  0  0      4992     24904  0  3   5   0  0  0  0  69 165 580 75 22  4  59
```

You can specify an interval, in seconds, at which `vmstat` updates statistical information. Statistics are then averaged over the last interval rather than since system boot. For example, to view updated information every 5 seconds, enter:

```
% vmstat 5
```

Field definitions for output are provided below.

The `procs` fields provide information about the number of processes in various states. You should find few blocked (`b`) jobs. If the system is busy, however, the count of active jobs (`r`) can be large, and several of these jobs may be blocked (`b`).

`r` Number of processes in the run queue (active jobs).

`b` Number of processes blocked for resources (for example, I/O and paging).

`w` Number of processes runnable or short sleeper but partially swapped. Short sleeper is under 20 seconds.

The `memory` fields provide information about use of virtual and real memory:

`avm` Number of kbytes allocated to active virtual memory.

`fre` Number of kbytes on free list (available for allocation).

The `page` fields provide information about page faults and paging activity:

<code>re</code>	Number of pages reclaimed from the swap device queue.
<code>at</code>	Number of pages reclaimed from free pool.
<code>pi</code>	Number of pages paged in.
<code>po</code>	Number of pages paged out.
<code>fr</code>	Number of pages freed.
<code>de</code>	Anticipated short-term memory shortfall.
<code>sr</code>	Number of pages scanned per second by the paging daemon. The paging daemon is active whenever available free physical memory is low. When the paging daemon is active, the <code>sr</code> field displays a nonzero value.

The `faults` fields provide trap/interrupt rates:

<code>in</code>	Device interrupts per second.
<code>sy</code>	Number of system calls per second.
<code>cs</code>	Number of CPU context switches per second.
<code>vs</code>	Number of vector switches per second.

The `cpu` fields provide information on CPU use:

<code>us</code>	Percentage of CPU time used by users.
<code>sy</code>	Percentage of CPU time used by the system.
<code>id</code>	Percentage of CPU time that was idle.

Ideally, system CPU use should be as low as possible. User processes are not being run if the system CPU use is high. High system overhead can be caused by excessive context switching (`cs`), interrupt activity (`in`), or system call activity (`sy`). Abnormal job distribution can signify system imbalances. For example, if processes are blocked (`b`), the disk subsystem is overloaded or imbalanced.

System overhead increases from 60% to 70% if devices begin sending spurious interrupts or if user programs do high-speed nonbuffered I/O. Use the `syspic` utility to detect the port causing the problem.

If the system is heavily loaded or has little memory available, the system is forced to swap. If the runnable processes (*w*) shows nonzero, the system is starting to swap, which significantly reduces system performance. The best way to avoid swapping is to add more memory. However, consider administratively limiting system load if you expect to remain in a memory-poor environment. For example:

- Require users to use batch queues instead of interactive tty sessions, because the batch system can enforce limits. Additionally, swapping does not matter as much for batch jobs, because the user is not waiting for a prompt. CXbatch is an optional product.
- Add more swap partitions on different disks to increase swap bandwidth.

Monitoring activity dynamically

The `syspic` utility displays statistics on current system activity, such as system processes, memory, paging, faults, network use, and load average on local machines. You can use this information to determine if there are any problem areas in the system. You can view statistics on a the disk subsystem, active processes, or the network. For example, to view statistics on system activity, run `syspic` by entering:

```
% syspic
```

Figure 8 illustrates the output from this `syspic` command.

Figure 8 sypsic window

Host System Activity				Users: 20	Current: Fri May 18 15:8:11 1992				
Load: 0.80 0.94 0.97				Up: 6 days, 12:30	Reboot: Sat May 12 02:47:26 1992				
Network I/O				Paging		CCU Busy		Tape, Mb/s	
lo0		ex0		Reclaims	0	ccu0	ta0 0.000		
In Packets	19258	33	6660986	Page Ins	2	ccu1	-		
In Errors	0 0	0	0	Page Outs	0	ccu2	-		
Out Packets	0 19258	28	4536642	Pgin	0.016M	ccu3	-		
Out Errors	0 0	0	827	Pgout	0.000M	ccu4	-		
Collisions	0 0	1	182172	Scan Rate	0.0M	ccu51%	-		
				Swap Ins	0	ccu6 8%	tot 0.000		
				Swap Outs	0	ccu7	CPU Usage		
Buffered I/O		TTY Totals			Memory Mb		User 3%		
Mb/s	0.003	ca	in	out	Virt.	84.914	User (n) 0%		
Latency,ms.	0	0	0	0	Real	46.488	System 6%		
Buffer Hits	100%	1	-	-	Free	6.906	Idle 91%		
Page Hits	100%	2	-	-	Processes				
Bufcache	20.359M	3	-	-	Runnable	1	Faults		
Deleted Wr	0.000M	4	-	-	Disk Wait	0	Interrupts 31		
Deferred Wr.	0.000M	5	-	-	Page Wait	0	System Calls 60		
Path. Cache		6	-	-	Swapped	0	Context Sw (p) 25		
Pathname Cache	88%	7	-	-	Sleeping	113	Context Sw (v) 0		
Calls/Hits	34/ 30	+	0	0					

The statistics are displayed in windows. The information in the windows is periodically updated. Numbers that indicate abnormal system loading are highlighted.

The first two lines on the display contain the following information:

Users	Number of users logged into the system.
Current	The last time a screen update occurred.
Load	Load averages representing the number of jobs waiting in the run queue over the last 1, 5, and 15 minutes.
Up	Elapsed time since the last reboot.
Reboot	Last time system was rebooted.

Each window and the information it provides is described in the following sections.

Network I/O

This window shows activity taking place on local area networks attached to the system. There are two columns of information for each device. The numbers in the first column are accrued since the last screen update. The numbers in the second column are accrued since the machine has been up. The devices shown depend on your network configuration. In Figure 8 the devices are `lo0` and `ex0`. The information displayed for `Network I/O` is:

In Packets	Number of packets received over the network. A packet is a group of bytes transferred over a network line.
In Errors	Number of receive errors accrued. Receive errors occur if there is something wrong with the packet being transferred (such as an incorrect header or corrupted data). Packets generating receive errors are thrown out.
Out Packets	Number of packets transmitted over the network. A packet is a group of bytes transferred over a network line.
Out Errors	Number of transmit errors accrued. Transmit errors occur if the system receiving the data rejects the packet.
Collisions	Number of packet collisions accrued. Collisions occur when more than one process attempts to transmit data over the same network line. If this happens, one process must wait until the line is freed before transmitting its data.

Collisions should be a small percentage of the total number of Out Packets. If Collisions become excessive, you might consider getting another subnet to reduce traffic on the existing lines.

Paging

This window shows information about page faults, paging activity, and swaps. The totals are 5-second averages displayed in units per second. For example, in Figure 8, two “Page Ins” per second occurred in the last 5 seconds.

Paging is a memory management technique that allows unused portions of a program to be stored temporarily on disk to make room for more urgently needed information in main memory.

The information displayed for Paging is:

Reclaims	Number of pages that were paged out from a process but were given back to the process before being allocated elsewhere.
Page Ins	Number of faults that resulted in pages being paged in. A page fault occurs when a process requests data that is not currently in main memory.
Page Outs	Number of times the pager tried to page from any region.
Pgin	Amount of megabytes paged in, per second, as a result of faults registered in the Page Ins field.
Pgout	Amount of megabytes paged out, per second.
Scan Rate	Rate at which the pageout daemon is running through physical memory and freeing pages. As the scan rate goes up, so does the number of pages freed and number of reclaims.
Swap Ins	Number of processes whose swap-priority-penalty was removed. Processes are not actually swapped when this occurs, but their priority is lowered for a period of time.
Swap Outs	Number of processes partially swapped. These processes may still run, but their priority remains low until their swap-priority penalty is removed.

CCU busy

This window shows what percentage of the time each CCU on the system is busy. If one CCU is excessively busy while others are not used, it is an indication that too many devices are concentrated on one IOP (VIOP or HSP). Consider reallocation of devices assigned to the CCUs.

Tape, Mb/s

This window shows the transfer rates of tape drives in megabytes per second. It also provides the sum total of these transfer rates. Fields with a dash "-" at the end of the line indicate there is no tape drive connected to that line.

Buffered I/O

This window shows parameters related to buffered user I/O and the buffer cache. Buffers are used to make I/O more efficient. Instead of performing many small transfers, one larger transfer is performed each time the buffer is full. The information displayed for Buffered I/O is:

Mb/s	Average amount of buffered I/O, in megabytes per second.
Latency, ms	Average amount of time, in milliseconds, that a request to the buffered I/O system took to complete.
Buffer Hits	Percentage of times a file system I/O request found the desired buffer pages already attached to a buffer header. (This value ranges between 0% and 100%.) Buffer hits cannot occur without a corresponding page hit.
Page Hits	Percentage of times an I/O request found the desired pages in the page cache. (This value ranges between 0% and 100%.) The page cache is a least-recently-used replaced cache containing both file system data and executable images. A page hit can occur without a corresponding buffer hit.
Bufcache	Effective size of the buffer cache, in megabytes. It is calculated by counting the number of pages attached to buffer headers.

- Deleted Wr. Amount of file system data, in megabytes, that was thrown away because the files containing it were deleted before they were written to the disk. Temporary files are often not written to the disk at all.
- Deferred Wr. Amount of file system data, in megabytes, that was scheduled to be written to disk but had the write deferred because another request for access to the data was made while the I/O request was on the disk queue.

TTY totals

This window displays the number of characters transmitted over the tty line since the last screen update. This total is the sum of all tty lines connected to each controller. Fields with a dash (-) at the end of the line indicate there is no tty line connected to that controller. The last line contains the sum of all tty lines. The information displayed for TTY Totals is:

- in Number of input characters transmitted.
- out Number of output characters transmitted.

Memory Mb

This window displays the following information, in megabytes, about use of virtual and real memory:

- Virt. Total amount of virtual memory that might require paging to swap space. Swap space is a region on a mass storage device where processes are stored when they are swapped out. With virtual memory, the system copies infrequently used pages of memory out to disk. When a process references a memory page that is not currently in physical memory, the system automatically brings in the requested page from disk.
- Real Total amount of memory that is in use by processes.
- Free Total amount of memory that is not in use.

CPU usage

This window displays the percentage of usage of CPU time. Percentages are calculated as averages among all existing processors. Information is displayed for the following categories:

User	Percentage of CPU time used for running normal-priority user processes.
User (n)	Percentage of CPU time used for running low-priority (niced) processes.
System	Percentage of CPU time used for running system code.
Idle	Percentage of time the CPU is idle.

Path cache

This window displays information about the path name cache. The path name cache is an area in memory that contains the path name and associated inode number for recently requested files. As the path name cache fills, the oldest path names are dropped.

Pathname	Percentage of successful lookups cache made to the path name cache.
Calls/Hits	Number of times a path name was requested versus the number of times the path name was found in the path name cache.

Processes

This window displays the following information about processes on the system:

Runnable	Number of processes trying to use the CPU.
Disk Wait	Number of processes waiting completion of disk or other short-term I/O operations, including paging and file requests.
Page Wait	Number of processes waiting for free memory pages, including memory for paging and file requests.
Swapped	Number of processes whose priority is lowered because they have been partially swapped.

Sleeping Number of processes that are temporarily suspended. Processes sleep while waiting for I/O fulfillment, the death of an offspring, or for a specific time interval to elapse.

Faults

This window displays trap/interrupt frequency averages per second over the last 5 seconds. A trap is a machine instruction used as the system call interface between application software and the kernel. When an application issues a trap instruction, the kernel takes over. The kernel performs the requested service and then resumes the application program.

Interrupts indicate a condition such as the arrival of data at an interface, the expiration of a timer, or the completion of a data transfer. Most interrupts are generated by peripheral devices. When an interrupt is activated, the current task is suspended while the instructions in the interrupt handler are performed. When the interrupt servicing is complete, the system resumes the original task. The major role of interrupts is to enable the system to supervise data transfers.

Interrupts	Number of interrupts, per second, not including the clock.
System Calls	Number of system calls, per second.
Context Sw (p)	Context switch rate, per second, for processes.
Context Sw (v)	Context switch rate, per second, for vectors.

Monitoring processes dynamically

For more information about processes, use the `syspic` utility with the `-p proc` argument. For example, enter:

```
% syspic -p proc
```

Figure 9 illustrates output for this command.

The statistics are displayed in windows. The information in the windows is periodically updated. Numbers that indicate abnormal system loading are highlighted.

```

Host System Activity          Users: 20      Current: Fri May 18 15:8:11 1992
Load: 0.80 0.94 0.97        Up: 6 days, 12:30      Reboot: Sat May 12 02:47:26 1992

Memory Mb
Virt.    85.898
Real     47.902
Free     5.609

Per-CPU Usage
          total cpu0cpu1
User     24%  25%  24%
User (n) 17%  19%  14%
System   41%  40%  41%
Idle     18%  17%  20%

USER      PID      %CPU    %MEM    SIZE  RSS    TT     STAT  TIME  COMMAND
smith    19909   20.9    1.9     7028  1056   p7     R     0:41  syspic -p proc
jones    19918   3.4     0.8     480   412    pe     S     0:00  mail
root     2266    2.7     0.8     1152  408    ?      S     1:07  xterm -sf -d star:0-
root     19916   1.9     0.3     184   140    ?      S     0:00  rstatd
jones    2299    0.7     0.6     404   344    pe     S     0:09  -tcsh
root     241     0.3     0.1     48    24     ?      S     34:08 /etc/update
brown    3405    0.2     0.2     692   112    p0     S     1:06  uxwindows
root     101     0.2     0.0     116   4      ?      S     51:23 /etc/nfsd 4
root     103     0.2     0.0     116   4      ?      S     51:15 /etc/nfsd 4
root     24533   2.9     0.9     1148  456    ?      S     0:30  xterm -sf -d moon:0 -

```

Figure 9 syspic -p proc output

The first two lines on the display contain the following information:

Users	Number of users logged into the system.
Current	The last time a screen update occurred.
Load	Load averages representing the number of jobs waiting in the run queue over the last 1, 5, and 15 minutes.
Up	Elapsed time since the last reboot.
Reboot	Last time system was rebooted.

Each window and the information it provides is described in the following sections.

Memory Mb

This window displays information, in megabytes, about use of virtual and real memory.

Virt.	The total amount of virtual memory that might require paging to swap space. Swap space is a region on a mass storage device where processes are stored when they are swapped out. With virtual memory, the system copies infrequently used pages of memory out to disk. When a process references a memory page that is not currently in physical memory, the system automatically brings in the requested page from disk.
Real	The total amount of memory that is in use by processes.
Free	The total amount of memory that is not in use.

Per-CPU usage

This window displays the percentage of usage of time as an average for each CPU in the following categories:

User	Percentage of CPU time used for running normal-priority user processes.
User (n)	Percentage of CPU time used for running low-priority (niced) processes.
System	Percentage of CPU time used for running system code.
Idle	Percentage of time the CPU is idle.

Additional information is provided about the 10 processes using the most CPU resources:

User	Login name of user who owns the process.
PID	Identification number for the process.
%CPU	Percentage of CPU the process is using.
%MEM	Percentage of real memory the process is using.
SIZE	Virtual size of the process in 1-kbyte units.
RSS	Resident set size. Real memory size of the process in 1-kbyte units.
TT	Control terminal where the process was initiated.
STAT	Status of process. This can be one of the following: V Vector processing is being used. R Runnable process. T Stopped process. P Process is in page wait. D Process is in disk or other short term wait. S An active process (sleeping for less than 20 seconds). I Idle process (sleeping longer than 20 seconds). Z Zombie process (trying to exit but parent process is not waiting for it). W Process is swapped out. P Process is partially swapped out. > Process is exceeding soft limit on memory. N Process priority is reduced. < Process priority has been artificially raised.
TIME	Amount of CPU time the process has used. It might be an indication of a runaway process if this time seems excessive. Talk to the user who started the process to see if the time used seems reasonable for the process running. If it is a runaway process, kill the process or have the user who owns the process kill it.
COMMAND	Command that initiated the process.

See the `sypsic(8)` man page for more details on what you can view.

Monitoring disk use

The `df`, `du`, and `quota` utilities monitor disk use:

- The `df` utility reports the amount of free disk space, in kilobytes, available in a file system.
- The `du` utility reports the number of kilobytes used by files and directory subtrees.
- The `quota` utility displays a user's current disk usage and limits.
- This section describes how to use these utilities.

Monitoring free disk space

If you specify a file system with the `df` command, `df` reports free space for the specified file system. If you specify a file with the `df` command, `df` reports on the free space for the file system where the specified file resides. If you do not specify a file or a file system, the `df` utility reports on all mounted file systems. For example, enter the following command to report on free space for the `/mnt` file system:

```
% df /mnt
```

Figure 10 illustrates sample output from this command.

Figure 10 Sample output from `df` utility

File system	Kbytes	used	avail	capacity	Mounted on
/dev/st6	163423	141277	5803	96%	/mnt

The total amount of disk space is reported in the `Kbytes` column. Entries in the `used` and `avail` columns totaled together will show 10% less than the total number in the `Kbytes` column. ConvexOS attempts to keep 10% of the disk unallocated to prevent disk fragmentation. See the `df(1)` man page for more details on this utility.

Monitoring used disk space

The `du` utility counts the actual number of disk blocks used, which is different from the `ls` command, which reports on the total file system size.

You can specify either a file or directory name with the `du` command. If you specify a file, you receive the number of kilobytes used by the specified file. (You must use the `-a` option to get file totals.)

If you specify a directory name, you receive totals for each directory within the specified directory, recursively. If you specify the `-a` option, you also get totals for the files within the specified directory, recursively.

If you do not specify a file or directory name, the `du` utility assumes the top of the file system for the current working directory.

To generate disk use totals for the `tmp` directory in user `smith`'s home directory, enter:

```
% du ~smith/tmp
```

Figure 11 illustrates sample output from this command.

Figure 11 Sample output from `du` utility

```
770      /mnt/smith/tmp/oper
1425     /mnt/smith/tmp/config
133      /mnt/smith/tmp/source/sysfiles
64       /mnt/smith/tmp/source/opfiles
599     /mnt/smith/tmp/source
2883    /mnt/smith/tmp
```

See the `du(1)` man page for more details on this utility.

Monitoring current use and limits

If your system uses quotas to control the amount of disk space used by users, use the `quota` command to display a user's current disk usage and limits. For example, to check the quota use for user `smith`, enter:

```
% /usr/ucb/quota -v smith
```

Figure 12 illustrates sample output from this command.

Figure 12 Sample output from the `quota` utility

```
Disk quotas for smith (uid 2500):  
Filesystem  usage  quota  limit  timeleft  files  quota  limit  timeleft  
/mnt        17     100    150           13     0     0
```

For more information on the `quota` utility, refer to the `quota(1)` man page.

Monitoring UUCP use

The `uusnap`, `uulook`, and `uuclean` utilities monitor UUCP activity and remove old UUCP files. This section describes how to use each of these utilities.

Monitoring pending UUCP activity

The `uusnap` utility generates a table showing the status of pending UUCP activity. Figure 13 illustrates sample output from this command.

Figure 13 Sample output from `uusnap` utility

```
smu          1 Cmd      -----TALKING
allegra      1 Cmd      -----
ctvax        1 Cmd      -----DIAL FAILED Retry time 53 mins
cual         ___      _____LOCKED
```

The columns describe, from left to right:

- System or resource name
- Number of outgoing commands
- Number of incoming or outgoing data files
- Number of commands queued for local execution
- Status message

The `LOCKED` status shown in row four indicates that the resource is being used and is unavailable for acquisition by another process. The status message can include the time remaining before UUCP can retry the call and the number of times UUCP has unsuccessfully attempted to reach the site.

For more information on the `uusnap` utility, refer to the `uusnap(8)` man page.

Monitoring the UUCP logfile

The `uulook` utility allows you to view the end of the UUCP logfile and monitor it, displaying new entries as they occur, until you send an interrupt (usually `CTRL-C`). Figure 14 illustrates sample output for the `uulook` utility.

Figure 14 Sample output from `uulook` utility

```
smith rice (2/15-12:41-985) SUCCEEDED (call to convex)
smith rice (2/15-12:42-985) OK (startup)
jones info (4/1-14:28-9574) FAILED HANDSHAKE (You are unknown)
```

The columns describe from left to right:

- Name of the user calling `uucp`
- Name of the system called
- Time and date of the call and the associated process ID
- Call status
- Status detail

See the `uulook(8)` man page for more details on this utility.

Removing old UUCP files

The `uuclean` utility removes old files from the `/usr/spool/uucp` subdirectories. Files that are removed are usually the result of interrupted `uucp` queuing or transmission procedures. The `uuclean` utility, typically run by `cron`, deletes all files in the spool directories older than a specified number of hours. Figure 15 illustrates a typical script run by `cron`.

Figure 15 Sample `uuclean` cron script

```
/usr/lib/uucp/uuclean -d/usr/spool/uucp/D.convex -n99 -pD.convex
/usr/lib/uucp/uuclean -d/usr/spool/uucp/C. -n169 -pC.
/usr/lib/uucp/uuclean -d/usr/spool/uucp/D. -n169 -pD.
```

Each line in the script begins with an invocation of `uuclean`. The `-d` option specifies the name of the subdirectory to be cleaned. The `-n` option specifies the number of hours old the file must be to be removed. The `-p` option specifies the prefix the file must match to be removed.

Refer to the `uuclean(8)` man page for more details on this command. Refer to Chapter 3, “Controlling processes,” on page 29, for information on the `cron` utility.

ConvexOS process control utilities allow you to schedule processes in the future and change execution priorities. This chapter describes how to use these utilities.

Changing process priorities

When a file is executed, it becomes a process. Each process has an execution priority associated with it based on the `nice` value of the process. The default `nice` value for a program run from a shell is zero.

You can alter a process's execution priority by altering the process's `nice` value. This can be done either when the process is invoked, using the `nice` utility, or after the process is invoked, using the `renice` utility. This section describes how to use the `nice` and `renice` utilities.

You can set the defaults for the `renice` utility by setting the `auto_nice_factor` boot-time parameter. Refer to Chapter 15, "Customizing kernel boot-time parameters," of the *Configuration Guide* for details on setting this parameter.

Specifying nice values

Use the `nice` utility when invoking a process to specify the process's nice value. The nice value is used to determine the process's execution priority.

The `nice` utility accepts as an argument a positive integer between 1 and 64, which increments the existing nice value. A higher number means a lower priority. That is, a process with a nice value of 5 runs before a process with a nice value of 10.

The superuser can increase the priority of a process between negative 1 and 64 using the `nice` utility by specifying a negative numerical argument. This will make the process run before other programs so it will take less time to finish.

For example, if a process `myprogram` has a nice value of 0, and you execute the following command, `myprogram` starts with a nice value of 3.

```
% nice +3 myprogram
```

If you do not specify a positive integer between 1 and 64, the `nice` utility increments the default process priority by 4.

Raising the priority to 3 or 4 causes jobs to run somewhat slower. Processes with a priority set at 64 run only when no other processes are running.

Note

Changing nice values

Once a process is started, the owner of the process can affect its execution priority by changing its nice value using the `renice` utility. You can change the nice value for a single process, all processes in a process group using the `g` option, all processes owned by a user with the `u` option, or any combination of these.

You need the process ID (PID) number of a process to change the nice value of a running process. You can get the PID number using the `ps` command. For example, if you know you have a program called `myprogram` running and you want to find its PID, enter:

```
% ps
```

You receive output similar to that shown in Figure 16.

Figure 16 Sample output for `ps` command

PID	TT	STAT	TIME	COMMAND
29911	p3	I	0:00	-csh[smith]
2017	p7	R	0:00	myprogram

The first column in the `ps` command output provides the PID number for myprogram. In this example, the PID is 2017.

Next, execute the `renice` command to change the process's nice value. For example, the following command sets the nice value to 3 for the process numbered 2017:

```
% /etc/renice +3 2017
```

The `renice` utility accepts as an argument a positive integer between 1 and 64, which changes the existing nice value. A higher number means a lower priority. That is, a process with a nice value of 5 runs before a process with a nice value of 10.

The superuser can specify any positive or negative value between -64 and +64. However, if you make the nice value very negative, the process cannot be interrupted. To regain control, make the nice value greater than zero.

Users other than the superuser can only alter the nice value of processes they own and only by a positive value. Users cannot increase nice values of their own processes even if they decreased the priorities in the first place.

Scheduling processes

The `at` utility executes specified commands once at a specified time and date. The `cron` utility executes specified commands either once or several times at specified times and dates. If you only want the process to run once, use the `at` utility. `cron` continues to run the command as long as the specified date matches the current date. This section describes how to use the `at` and `cron` utilities.

Scheduling future one-time execution

Use the `at` utility to schedule automatic execution of a shell script or program at a specified time and date. The time can be from one to four digits long. One- and two-digit times are assumed to be hours. Three- and four-digit times are assumed to be hours and minutes. For example, `435` is interpreted as 4:35 a.m.

You can optionally include an `a` for a.m., `p` for p.m., `n` for noon, or `m` for midnight with the time specification. For example, `1200n` is interpreted as noon. If no letters follow the time digits, a 24-hour clock time is used.

You can optionally include a day of the month or day of the week. Specify a day of the month by including a month name followed by a day number. For example, specify `jan 24` to schedule execution on January 24.

Specify a day of the week instead of a date by simply specifying the day name. Add `week` after the day name to schedule a week ahead. For example, specify `fr week` to schedule execution on Friday of next week. If you just specify `week` without a day name, execution is seven days from the current date.

If a day is not specified, the current day is assumed. Names of months and days can be truncated.

For example, to schedule execution of a program called `big.program` at 4:00 a.m. on January 24, enter

```
% at 4am jan 24 big.program
```

The `at` utility copies the specified script to the `/usr/spool/at` directory as a process file. When the time specification is met, the `atrun` utility executes the process file. The `atrun` utility is normally executed every 15 minutes by the `cron` utility.

You can create a shell script of commands to execute using the `at` utility. For example, if you want to execute the `ls` command at 4:00 a.m. on the current day, enter the following commands

```
% at -C ls -f ls.script
```

```
% at 4am ls.script
```

The first command specifies the command you want executed (`ls`) and places it in an output file called `ls.script`. The second command schedules the `ls.script` file to execute at 4:00 a.m. on the current day. The `-C` option specifies that there is only a single command to execute.

If you want to schedule multiple commands to execute at a specified time without first placing them in a shell script, use the `at` command without specifying the `-C` option or an input file name. The `at` utility prompts for commands from standard input until you press `CTRL-d`. Figure 17 illustrates a sample interactive `at` session.

Figure 17 Sample interactive `at` session

```
% at 4am
at> cd ..
at> ls -l
at> <EOT>
```

The `at` utility copies the specified script to the `/usr/spool/at` directory as a process file. When the time specification is met, the `cron` utility executes the process file.

See the `at(1)` man page for more details on this command.

Scheduling multiple-time executions

`cron` executes commands at specified dates and times according to the instructions found in the `/usr/lib/crontab` file or any `.crontab` file residing in a user's home directory. Use the `cron` utility to automatically execute commands, at regular intervals. For example, you can use `cron` to:

- Truncate growing files on a regular basis
- Search for and delete out-of-date messages
- Remove editor checkpoint files
- Print system statistics
- Start up UUCP for regular calls

Each line of the crontab file represents one activity; fields in each line are separated by spaces or tabs. The first five fields in a crontab entry are integers that specify when the command should be performed. The format is

minute hour date month day command

where

minute is any number between 0 and 59, inclusive.

hour is any number between 0 and 23, inclusive.

date is any number between 1 and 31, inclusive.

month is any number between 1 and 12, inclusive.

day is any number between 1 and 7, inclusive. One (1) indicates Monday, two (2) indicates Tuesday, three (3) indicates Wednesday, and so on.

command is the command that is executed when the time element is met. A percent character in this field is translated as a newline character.

Each of the first five fields can be a single value or a list of values separated by commas. Use an asterisk to specify all legal values. To specify an inclusive range, separate two numbers with a minus sign. Figure 18 illustrates a sample `/usr/lib/crontab` file.

Figure 18 Sample `/usr/lib/crontab` file

```
0 1 * * * yourprogram
0 9-17 * * 1-5 myprogram
```

The first line in this example runs `yourprogram` at minute 0 of hour 1 (1:00 a.m.) every day, specified by the asterisk in the day, month, and day of week fields. The second line runs `myprogram` at minute 0 of hours 9 through 17 (9:00 a.m. until 5:00 p.m.) on Monday through Friday, every week of the month.

The `cron` utility produces a variety of messages about syntax errors, file-access errors, and illegal use errors. Messages are handled by `syslogd` or mailed to the user. Commands are not executed if they generate an error message.

`cron` updates its task list once an hour. To force an update, use the `tellcron` utility. This informs you of any syntax errors immediately.

See the `cron(1)` and `crontab(5)` man pages for more details on the `cron` utility.

Managing the line printer system

4

The line printer system is a collection of programs and files that manage printer operations. This includes setting up the spool system, handling print requests, managing queues, and enabling and disabling printers. This chapter describes how the line printer system works and introduces programs you will use to maintain the line printer system on a day-to-day basis.

Instructions for configuring new printers are found in the following chapters:

- Chapter 2, “Adding devices,” on page 21 in the *Configuration Guide*, describes operating system files you need to modify to add a new printer to the system.
- Chapter 5, “Setting up the line printer system,” on page 129 in the *Configuration Guide*, describes procedures for configuring printers and creating spool directories.

Error messages are listed in Appendix A, “Line printer system error messages,” in this guide.

Refer to the *ConvexOS Primer* for information on using the line printer system and submitting print jobs with the `lpr` command.

The line printer daemon

ConvexOS handles many tasks in the system by using daemons. A daemon is a system process, usually started at boot time, that handles repetitive system functions in the background. A daemon usually lives as long as the system is running and waits between requests.

The line printer daemon is called `lpd`; it is started from the `rc.std` script at boot time and takes care of numerous tasks in the line printer system. When `lpd` is invoked, it scans the `/etc/printcap` file to determine what printers are on the system and prints files that were left in the queues when the system went down. After it has taken care of these tasks, `lpd` is ready to process new requests.

The line printer daemon handles requests to:

- Transfer files to the spooling area
- Transfer files between queues
- Display a printer queue
- Remove files from a queue
- Print files in the queue

`lpd` uses sockets to handle requests. When a request is received, `lpd` forks a child process to handle the request so the parent `lpd` process can listen for additional requests. Consequently, there may be several copies of `lpd` running at the same time.

When a user submits a print request with the `lpr` command, the file is first copied into a dedicated spooling directory within the `/usr/spool` directory. For example, files sent to the default line printer might be queued in the directory `/usr/spool/lpd`. From here, the file is processed by `lpd` and printed on a local printer or transferred to a remote host for printing on a remote printer.

To watch `lpd` work, look in `/usr/spool` for a file called `lpd.lock` and for the `lpd` directory. The `/usr/spool` directory is the default spool directory. The actual spool directory for a given printer is specified in the `sd` field of the `/etc/printcap` file. The `lpd` directory contains three files called `.seq`, `lock`, and `status`. You can list the `lpd` directory contents with the `ll -a` command.

The `.seq` file contains the queue sequence number of the next job to be queued. The lock file contains two lines: the PID of the daemon assigned to the line printer and the job ID of the job currently printing (or the last one printed). The status file contains a line describing the status of the printer (for example, active and printing, needs paper). This line is written into the status file by a daemon that communicates with the line printer device driver, or by the `lpc down` command (see the next section, “Managing printers”). The `lpq` command reads the status file to determine the status of the line printer queue.

`lpd.lock` is a lock file used by the master printer spooler to hold the PID of the `lpd` process. The master spooler coordinates all print requests and directs jobs among printers attached to the system.

Managing printers

The `lpc` (line printer control) utility is the primary tool for managing the line printer system. It allows you to control and maintain the operation of printers described in the `/etc/printcap` file. You can use the `lpc` utility to:

- Start or stop a printer
- Redirect a print queue
- Enable or disable print queues
- Rearrange the order of jobs in a queue
- Display the status of a printer, its daemon, and its queue

The format for the `lpc` utility is

```
lpc [command [parameter ...]]
```

where

command is an `lpc` command. This can be one of the following:

<code>abort</code>	Disable a printer immediately.
<code>clean</code>	Remove files in a printer queue.
<code>disable</code>	Disable a printer queue.
<code>down</code>	Disable printing and queuing; put message in status file.
<code>enable</code>	Enable a printer queue.
<code>exit</code>	Exit the <code>lpc</code> utility.
<code>help</code>	Provide help on available commands.
<code>redirect</code>	Redirect jobs from one printer to another.
<code>restart</code>	Restart a printer daemon.
<code>start</code>	Enable printing on a printer.
<code>status</code>	Display printer status.
<code>stop</code>	Disable printing on a printer.
<code>quit</code>	Exit the <code>lpc</code> utility.
<code>topq</code>	Place a job at the top of the print queue.
<code>undirect</code>	Remove redirection from a printer.
<code>up</code>	Enable printing and queuing; remove message from status file.
<code>?</code>	Provide help on available commands.

parameter is a parameter or list of parameters for the command. Typically, this is the name of a printer or `all` to specify all printers. If no parameter is given, most `lpc` commands return a usage message such as:

```
Usage: restart {all | printer ...}
```

If `lpc` is invoked without arguments, it runs interactively and displays the following prompt:

```
lpc>
```

When entering commands, you can specify the first few letters of the command instead of the entire command name. The `lpc` utility recognizes abbreviations, providing you supply enough letters to distinguish one command from another. This works in both interactive and noninteractive modes. For example, the `clean` command may be shortened to `c` while the `status` command may only be abbreviated to `stat` in order to distinguish it from the `start` command. If you enter an abbreviation that is ambiguous, `lpc` responds with the message

```
?Ambiguous command
```

You can use either the `exit` command or the `quit` command to exit the `lpc` utility. The end of file character, **CTRL-d**, is also recognized as a command to quit `lpc`.

Getting help

The `lpc` utility provides online help with the `help` or `?` command. The `help` command gives a short description of each command in the argument list. For example,

```
lpc> help status
```

displays a one-line description of the `status` command:

```
status          show status of daemon
```

If no arguments are given with the `help` command, the list of valid commands is displayed. Use the `help` command whenever you are uncertain about the function of an `lpc` command.

Starting and stopping printer daemons

The `lpc start` and `stop` commands control the line printer daemon, `lpd`. To stop a printer daemon, execute the `lpc stop` command. When you issue a `stop` command, `lpc` waits for the current job (if any) to finish printing. When the job is complete, the daemon for that printer is stopped. An example of the `stop` command is:

```
lpc> stop myprinter
```

You can also issue the `stop` command to all printers by entering:

```
lpc> stop all
```

The `stop` command does not disable queuing of print jobs. Users can submit new jobs to a stopped printer; the jobs wait in the queue until a daemon is started.

To start the printer daemon again, use the `start` command

```
lpc> start myprinter
```

or

```
lpc> start all
```

The `lpc abort` command also disables printing to any or all printers. It differs from the `stop` command by not waiting for the current job to finish printing before stopping the printer. When issued, the `abort` command terminates the printer daemon immediately. The `abort` command does not disable queuing of print jobs.

Restarting a printer

One of the most common uses of `lpc` is to restart a printer daemon. When a printer daemon dies, jobs pile up in the queue and nothing is printed. To restart the printer, use the `restart` command as shown below:

```
lpc> restart myprinter
```

You can use several methods to determine whether a printer has lost its daemon:

- The `lpc status` command shows the status of daemons and queues on the local machine.
- You can exit `lpc` and use the `lpq` command from the shell to examine printer queues. The output from `lpq` shows you all pending print jobs and notifies you of any error conditions with the printer or the printer daemon.
- You can use the `ps` and `grep` commands as shown in Figure 19.

Figure 19 Checking for an active `lpd` process using `ps` and `grep`

```
% ps ax | grep lpd | grep -v grep
303 ?    I      0:44 /usr/lib/lpd -f /etc/hosts.equiv
```

If no `lpd` process is displayed, restart the daemon. If an `lpd` process is displayed, a printer daemon exists, and a restart is not necessary.

Enabling and disabling queues

The `enable` and `disable` commands control printer queues. When a `disable` command is issued, the printer queue is turned off and no new jobs are queued. However, any job in the queue is printed. If anyone attempts to submit new jobs to the printer using `lpr`, the following warning message is displayed:

```
lpr: Printer queue is disabled
```

The `enable` command reverses the effect of the `disable` command.

Redirecting queues

The `lpc redirect` command allows you to redirect print jobs from one printer queue to another. The format of the `redirect` command is:

```
redirect [all] source destination
```

When you issue the `redirect` command, jobs submitted to the *source* printer are redirected to the *destination* printer. If you specify `all` in the command line, the `redirect` command redirects all jobs submitted from anywhere on the network. Otherwise, only jobs submitted from the machine where `redirect` was issued are affected.

Use the `undirect` command to remove redirection from a printer. The format of this command is:

```
undirect [all] printer
```

printer is the source printer specified in the `redirect` command.

Manipulating jobs in the queue

The contents of a printer queue can be adjusted using the `topq` and `clean` commands. The `topq` command moves print jobs to the top of the queue, causing those jobs to print first. You can move a job by its job number or by entering the user name of the job's owner. In the latter case, all print jobs owned by the user in the specified queue are moved to the top of the queue. For example, the command

```
lpc> topq myprinter 123
```

would place job number 123 at the top of the queue. The following example specifies a user name:

```
lpc> topq myprinter jones
```

The `clean` command deletes all files from the printer queue that begin with the letters `cf`, `tf`, or `df`. This command also removes any files remaining from failed jobs.

Scheduling downtime

When you need to disable a printer for things such as scheduled maintenance, use the `down` command. This command is similar to the `disable` command, except that it allows you to enter a message that is displayed when the `lpq` or `lpc status` commands are used to examine queue information. The message you enter is written to the status file in the printer's spool directory and remains until you enable the queue with the `lpc enable` command.

An example of the `lpc down` command is:

```
lpc> down myprinter Down for maintenance.
```

To enable the printer, use the `up` command. The `up` command reverses the effect of the `down` command, enabling the printer and removing the message from the status file. An example of the `up` command is:

```
lpc> up myprinter
```

Managing queues

In addition to the `lpc` commands that allow you to examine and adjust information in printer queues, three other utilities can help in managing queues:

- `lpq`
- `lpmv`
- `lprm`

These utilities are not part of the `lpc` utility; they are invoked directly from the shell. Each is described below.

Checking printer queues

You can determine status of a queue and display the list of jobs waiting to be printed using the `lpq` utility. The status typically reported by `lpq` includes whether the daemon is active or disabled, and whether the printer is currently printing, out of paper, or idle.

The format of `lpq` is

```
lpq [+n] [-f] [-l] [-Pprinter] [job#] [user]
```

where

- | | |
|-------------------------------|---|
| <code>+</code> | displays the queue until it is empty. If you supply a number immediately after the <code>+</code> , <code>lpq</code> sleeps for that many seconds between scans of the queue. |
| <code>n</code> | specifies the number of seconds <code>lpq</code> should sleep between queue scans (refer to the <code>+</code> option). |
| <code>-f</code> | displays the queue forever. When this option is specified, all other arguments are interpreted as user names or job numbers. This option overrides <code>+<i>n</i></code> . |
| <code>-l</code> | displays information about each file in the print job. |
| <code>-P<i>printer</i></code> | specifies the print queue. If the <code>-P</code> option is not specified, the default print queue is displayed or the queue specified by the <code>PRINTER</code> environment variable is used (providing this variable is set). |
| <code>job#</code> | displays a specific job in the queue identified by its job number. |
| <code>user</code> | displays all jobs for a user. |

If no arguments are supplied, `lpq` displays the default queue or the queue specified by the `PRINTER` environment variable (providing this variable is set).

An example printer-queue status request using the `lpq` utility is shown in Figure 20.

Figure 20 Example `lpq` output

```
% lpq -Pmyprinter
myprinter is ready and printing
Rank   Owner   Job   Files   Total Size
active smith   322   testplan 2896734 bytes
1st    jones   92    chap02   3469 bytes
```

Moving print jobs between queues

The `lpmv` utility moves jobs from one printer queue to another. Because spool directories are protected from normal users, `lpmv` is the only way users can move their jobs between queues.

The format of `lpmv` is

```
lpmv [-a] [-Pprinter] [user] [job#] destination
```

where

- `-a` moves all jobs owned by user invoking `lpmv`.
- `-Pprinter` specifies the source print queue. If the `-P` option is not specified, the default printer queue is used.
- `user` moves all jobs for a user. This option is useful for system managers to move a user's files all at once. root can specify multiple users.
- `job#` moves a specific job in the queue identified by its job number.
- `destination` is the name of the printer that you want to transfer jobs to.

If no arguments are supplied, `lpmv` moves the currently active job (if owned by the user) to the destination printer. The job is restarted on the new printer.

The `lpmv` utility displays the names of files it moves. Nothing is displayed if a match is not found. When `lpmv` moves a file, it may kill an active daemon. If the daemon is killed, `lpmv` automatically restarts a new daemon after moving the specified files.

An example of an `lpmv` request is:

```
% lpmv -a -Pmyprinter newprinter
```

Removing print jobs from queue

The `lprm` utility removes jobs from a print queue. Because spooling directories are protected from normal users, `lprm` is the only way a user can remove a job from the queue.

The format of `lprm` is

```
lprm [-Pprinter] [-] [job#] [user]
```

where

- `-Pprinter` specifies the print queue. If the `-P` option is not specified, the default printer queue is used.
- `-` removes all jobs owned by the user invoking `lprm`. If you are logged in as superuser, this option removes all jobs in the queue.
- `job#` removes a specific job in the queue identified by its job number.
- `user` removes all jobs for a user. This option is useful for system managers to remove all files owned by another user.

If `lprm` is used without arguments, it deletes the currently active job if it is owned by the user who invoked `lprm`. The `lprm` utility displays the names of files it removes. If nothing is displayed, no match was found. When removing files, `lprm` may kill an active daemon. If the daemon is killed, `lprm` automatically restarts a new daemon after removing files from the queue.

An example of an `lprm` request is:

```
% lprm -Pmyprinter 17
```

Maintaining striped file systems

5

Various ConvexOS utilities provide means of manipulating and monitoring disks within striped file systems. This chapter discusses tools for maintaining the availability of your file systems, including:

- Replacing stripe partitions
- Tracking hot spare status
- Reclaiming hot spare space

Replacing stripe partitions

In some situations, you may wish to replace one disk with another. This section explains how to substitute one disk partition for another in a stripe without dismantling and rebuilding the stripe.

This procedure assumes that all of the disks in question are part of your present disk system. For information on adding disks to your disk system, see the "Setting up the disk system" chapter of *Managing ConvexOS: Configuration Guide*.

For example, suppose partitions `du1g` and `du1h` are part of stripes `st0` and `st1`, respectively. `st0` is a redundant stripe and is mounted on `/foo`; `st1` is a nonredundant stripe and is mounted on `/bar`. You want to replace `du1g` and `du1h` with `du5g` and `du5h` respectively.

Note

It is not necessary to unmount a redundant stripe before using `mvst` on it.

- Step 1** Log in as root. If all the partitions to be moved are part of redundant stripes, skip to Step 4.
- Step 2** Check any affected nonredundant stripe partitions using `fstat` to make sure there are no open files.
- Step 3** For nonredundant stripes, unmount the striped file systems containing the partitions to be replaced using the `umount` command. For example:

```
# umount /bar
```

Caution

Double check the arguments you plan to give `mvst` using `mvst -nv` before actually issuing the `mvst` command. If you wish to stop a `mvst`, you must use `kill -15 <pid>` to do so. Stopping `mvst` via any means except a `kill -15` signal results in the loss of all data on the stripe device.

- Step 4** Move the stripe data from the old to the new disk partition(s) using the `mvst` command.

```
# mvst st0 du1g du5g dkd-502
```

```
# mvst st1 du1h du5h dkd-502
```

- Step 5** Remount nonredundant striped file systems using the `mount` command:

```
# mount /dev/st1 /bar
```

Tracking hot spare status

When a disk in a redundant stripe fails, the virtual volume manager (VVM) checks to see if a hot spare is available for the affected partitions. If so, VVM reconstructs the data from that disk on the specified hot spare device and continues operations. VVM sends messages to the console regarding the failed disk, notes the percentage of the hot spare used, and keeps track of the amount remaining.

Under normal circumstances, VVM can maintain accessibility of redundant file systems as long as hot spare devices are available. If you choose to use hot spares on your system, track hot spare availability and reclaim space when necessary so that VVM can maintain uninterrupted disk access.

Use the `getst` command as root to view hot spare status. For each hot spare, `getst` displays information in the format shown in Figure 21.

Figure 21 `getst -H` output format

```
# getst -H
hot spare hs0: du9a (64, 2305), sector size 2048 bytes, length 49200 Kbytes
                49200 Kbytes used [100#]
                affinity towards st0
                space in use by st0
```

Note that the hot spare in Figure 21 (hs0) is full, and thus would be unavailable for use should a disk in st0 fail.

Reclaiming hot spare status

If the procedure in the previous section reveals that a hot spare is full, or close enough to full that it would be of no use in the event of a crash, use the following procedure to reclaim space on the hot spare:

Step 1 Find out which stripe uses the hot spare.

```
# qst du9a
/dev/rdu9a is used in stripe st1 (redundant)
```

Step 2 For each stripe using the hot spare, select another disk partition to hold the data now residing on the hot spare. The examples in this procedure use du7a as the selected partition.

Step 3 Remove the hot spare to be reclaimed from the hot spare list:

```
# rmst -h du9a
```

Step 4 Use the `getst` command to identify the file system mounted on the stripe.

```
# getst st1
stripe st1: sector size 2048 bytes, mounted on /foo
           section a: size 271296 Kbytes/partition,
                       blocking factor 8 Kbytes
           .
           .
```

Step 5 If the stripe is nonredundant, unmount the file system.

```
# umount /foo
```

Step 6 Move the data on the hot spare to the disk you selected in Step 2.

```
# mvst st1 du9a du7a dkd-502
```

Step 7 Remount the file system on the stripe device:

```
# mount /dev/st1 /foo
```

Step 8 If more than one stripe uses the hot spare, repeat Step 4 through Step 7 for each stripe.

Step 9 Return the reclaimed hot spare to the hot spare list:

```
# newst -H du9a dkd-502
```

Generating accounting reports

6

The accounting system tracks system resources used by individuals and groups of users. From the information collected through the accounting system, you can determine how much disk space, line printer and tape use, or connect time a user or group consumes; how much CPU time is split between users and overhead; and which programs consume the most CPU cycles. With this information, you can:

- Plan system use
- Manage system resources
- Keep strict accounting of project costs

This chapter discusses how to generate accounting reports using information collected through the accounting system.

Collecting information

The accounting system is based on users, groups, and activities. Users belong to groups; the tasks they perform are called activities; and a billing account is a group paired with an activity.

The accounting system collects the following types of data:

- Process terminations
- Login times
- Successful and unsuccessful executions of `bill`
- Tape allocations and deallocations
- Tape error messages
- Printer use
- Printer use errors

Most accounting data is collected in logs in the `/usr/adm` directory:

- Process terminations are logged in `/usr/adm/acct`.
- Login times are collected in `/usr/adm/wtmp`.
- Successful executions of the `bill` command are collected in `/usr/adm/bill-acct`.
- Unsuccessful executions of the `bill` command are collected in `/usr/adm/bill-errs`.
- Tape use data is collected in `/usr/adm/tp-acct` and `/usr/adm/opreq-acct`.
- Printer use data is collected in `/usr/adm/lpd-acct`.

This relationship is illustrated in Figure 22.

Figure 22 Input for accounting log files

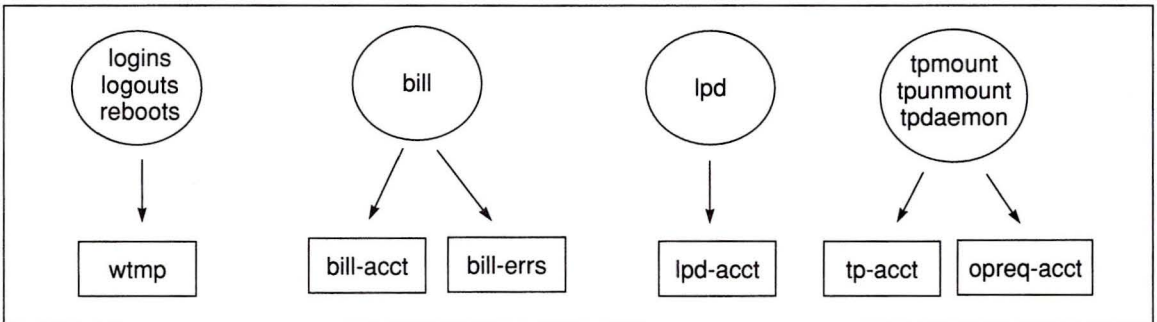

Accounting records the following information for each process:

- Process name
- User, group, and activity IDs
- Start time
- Total time run
- Total CPU time
- Total user time
- Total group time
- Controlling tty
- Memory usage
- Disk accesses

Automatic report generation

Daily, weekly, and monthly accounting reports are automatically generated by the `cron` utility. The `cron` utility executes scripts located in `/usr/adm` named `daily`, `weekly`, and `monthly` at the appropriate times.

The `daily` script copies accounting data from the `/usr/adm/acct` file to a file named `daily#`, where `#` is the day of the week the accounting data is generated. For example, if Sunday is considered the first day of the week, on Sunday accounting data is copied to a file called `daily0`. Using the `sa` utility, the `daily` script generates the following files from the data stored in the `/usr/adm/acct` file:

- `usracct#` (where `#` is the day of the week the report is generated)
- `savacct#` (where `#` is the day of the week the report is generated)
- `usracctw`
- `savacctw`
- `usracctm`
- `savacctm`
- `daily.u`

The `savacct` files contain usage totals for each process, and the `usracct` files contain usage totals for each user and each unique group/activity combination. Files ending with “w” contain running totals for the week, and files ending with “m” contain running totals for the month. The `/usr/adm/daily.u` file contains the daily totals for each user in readable text format. After all these files are created, the data in the `/usr/adm/acct` file is removed.

The `weekly` script generates the following files from the data stored in the `usracctw` and `savacctw` files in `/usr/adm`:

- `u.w.month.day.yr`
- `s.w.month.day.yr`
- `week.u`

month is the month the report is generated, *day* is the day it is generated, and *year* is the year it is generated. The `/usr/adm/week.u` file contains weekly totals for each user in text format.

The `monthly` script generates the following files from the data stored in the `usracctm` and `savacctm` files:

- `u.m.month.yr`
- `s.m.month.yr`
- `month.u`

`month` is the month the report is generated and `year` is the year it is generated. The `/usr/adm/month.u` file contains monthly totals for each user in text format. Figure 23 illustrates this relationship.

Figure 23 Generated accounting reports

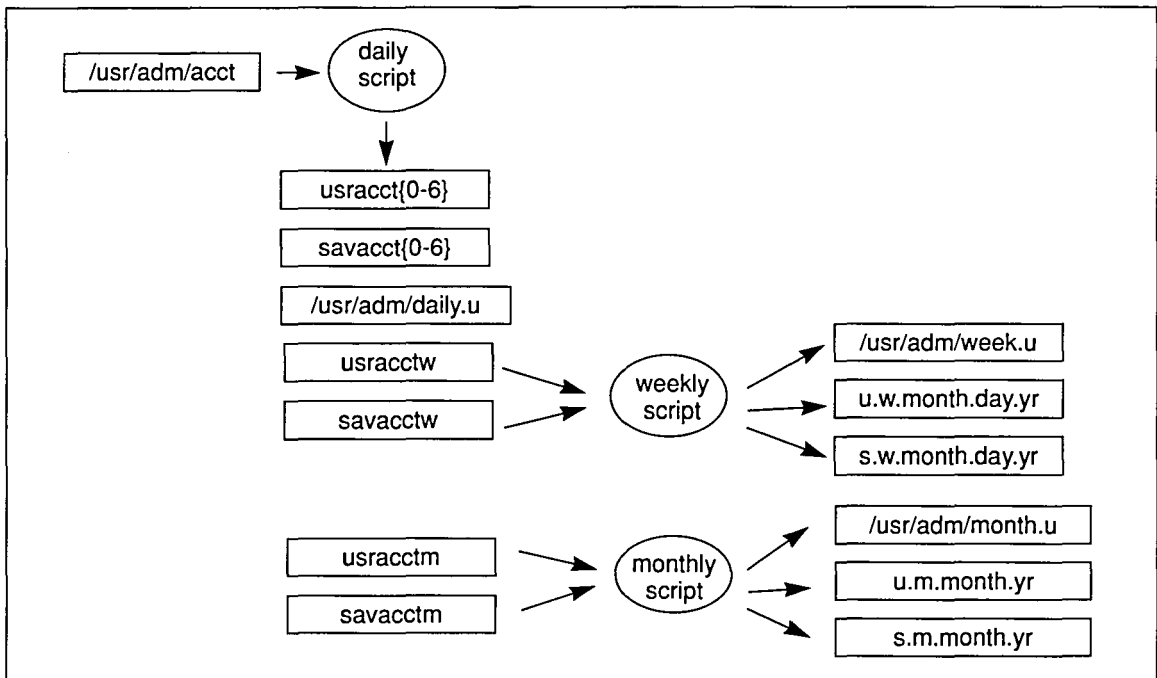

Manual report generation

ConvexOS provides summary utilities to process accounting data. These are:

- `connecttime`—The `connecttime` utility processes information from login, logout, and bill executions.
- `pac`—The `pac` utility summarizes printer use data.
- `diskuse`—The `diskuse` utility provides disk use totals for users and groups.
- `sa` and `lastcomm`—The `sa` and `lastcomm` utilities summarize process termination data.

The output from these utilities can be summarized in various formats by piping the output through data-specific `awk` scripts located in `/usr/adm/sumscripts`. These include:

- `connecttime.awk`—Pipes the information processed with the `connecttime` utility through the `connecttime.awk` script.
- `sabygrp.awk` and `sabyact.awk`—Pipes the information processed with the `sa` utility through the `sabygrp.awk` and `sabyact.awk` scripts.
 - The `sabygrp.awk` script formats the accounting data by group.
 - The `sabyact.awk` script formats accounting data by activity.
- `diskbygrp.awk`, `diskbyusr.awk`, and `diskmerge.awk`—Pipes the information processed with the `diskuse` utility.
 - The `diskbygrp.awk` script formats the accounting data by group.
 - The `diskbyusr.awk` script formats the accounting data by user.
 - The `diskmerge.awk` script merges totals taken at different times to report running totals over a period of time.

There are also some general summary `awk` scripts located in `/usr/adm/sumscripts` that summarize data in various formats. The general summary `awk` scripts include:

- `tape.awk`—Uses the `tape.awk` script to process the information in the `/usr/adm/tp-acct` file.

- `genbyact.awk`, `genbygrp.awk`, `genbygrpact.awk`, and `genbyusr.awk`—Summarizes the `/usr/adm/lpd-acct` output from the `tape.awk` script, and the output from the `connecttime.awk` script.
 - The `genbyact.awk` script summarizes accounting data by activity.
 - The `genbygrp.awk` script summarizes accounting data by group.
 - The `genbygrpact.awk` script summarizes accounting data by group and activity pair.
 - The `genbyusr.awk` script summarizes accounting data by user.

Figure 24 illustrates the relationship between `awk` scripts, accounting files, and summary utilities.

Figure 24 `awk` script relationship to files and summary utilities

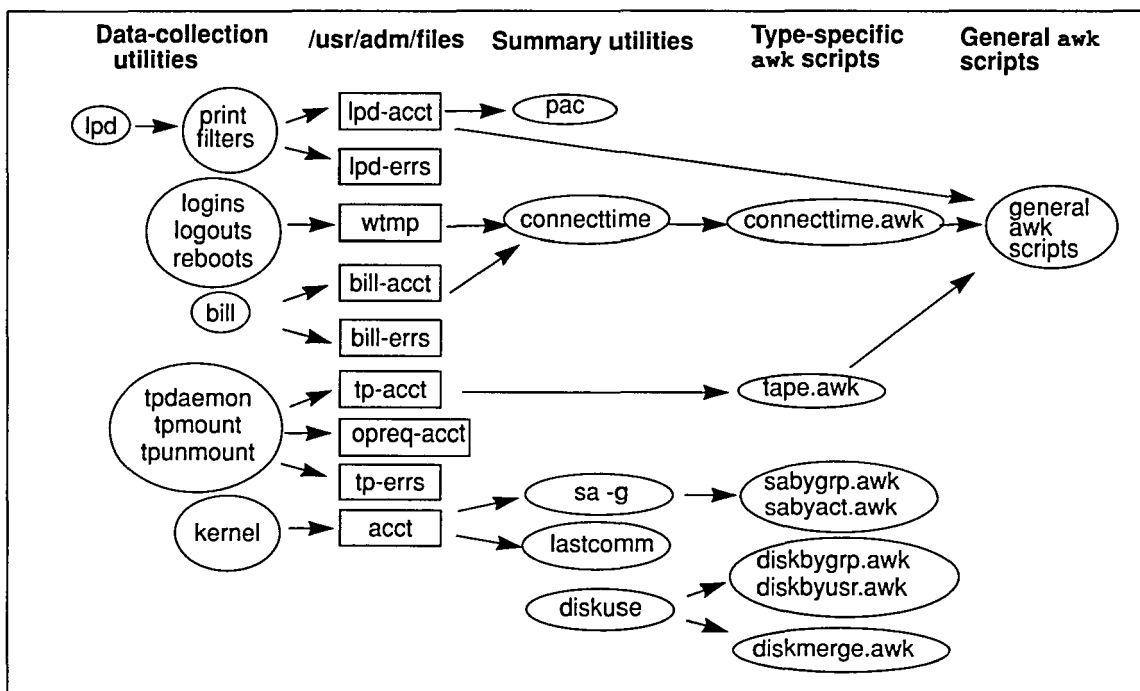

Summarizing process termination data

Process termination data is logged in the `/usr/adm/acct` file, a binary data file. You can use the `sa` and `lastcomm` utilities to translate the information in the `/usr/adm/acct` into a text file.

By group and activity combinations

Use the `sa` utility to generate a report on process termination data organized by group and activity combinations. The `sa` command format is

```
sa [options] [acct_file]
```

where

acct_file is the file to process. The default accounting file is `/usr/adm/acct`.

options control what information is included on the report and the way it is presented. Some of the more common options are listed below. See the `sa(8)` man page for details on other available options.

- `c` Include percentage of total time on report.
- `d` Sort records by average number of disk I/O operations.
- `D` Print and sort records by average number of disk I/O requests.
- `e` Echo records exactly as they appear in the accounting file.
- `g` Print totals for each group and activity combination.

You can direct the output to a file; otherwise, it is printed on the display screen. For example, to generate a file called `report` that contains accounting information for each group and activity combination, enter the following command:

```
% sa -g > report
```

Figure 25 illustrates the output you would receive from this command.

Figure 25 Sample `sa -g` output

swtst	admin	26670	235.17 cpu	2822202tio
staff	marv	682	9.16 cpu	6777tio
staff	vc	49196	361.05 cpu	234357tio

↑ ↑ ↑ ↑ ↑
 Group Activity # of commands executed Total CPU time Total I/O operations

You can optionally summarize the output of the `sa -g` command by piping it through one of two `sa` `awk` scripts located in `/usr/adm/sumscripts`: `sabyact.awk` or `sabygrp.awk`.

Use the following command to pipe `sa -g` output through the `sabygrp.awk` script:

```
% sa -g | awk -f /usr/adm/sumscripts/sabyact.awk
```

The `sabyact.awk` script summarizes the accounting data by activity. Figure 26 illustrates the output from the `sabyact.awk` script.

Figure 26 Sample `sabyact.awk` script output

admin	26670	235.17cpu	2822202tio
marv	682	9.16cpu	6777tio

↑ ↑ ↑ ↑
 Activity # of commands executed Total CPU time Total I/O operations

Use the following command to pipe `sa -g` output through the `sabygrp.awk` script:

```
% sa -g | awk -f /usr/adm/sumscripts/sabygrp.awk
```

The `sabygrp.awk` script summarizes the accounting data by group. Figure 27 illustrates the output from the `sabygrp.awk` script.

Figure 27 Sample `sabygrp.awk` output

swtst	26670	235.17cpu	2822202tio
staff	682	9.16cpu	6777tio

↑ ↑ ↑ ↑
 Group # of commands executed Total CPU time Total I/O operations

By command execution sequence

Use the `lastcomm` utility to generate a report on process termination data organized in order of most recent to least recent command executed. The command format is

```
lastcomm [-f acct_file] [command] [user_name] [term_name]
```

which has the following components:

acct_file File to process. The default file is `/usr/adm/acct`. You can specify an alternate file name using the `-f` option.

command Command to match

user_name User name to match

term_name Terminal name to match

When executed with no arguments, information about all commands recorded in the specified accounting file is printed. If arguments are included, only the accounting entries that match the argument criteria are used. For example, the following command produces a listing of all executions of commands named `a.out` by user `root` on terminal `ttyd0`:

```
% lastcomm a.out root ttyd0
```

See the `lastcomm(8)` man page for more details on using this utility.

Figure 28 illustrates sample output from this command.

Figure 28 Sample `lastcomm` utility output

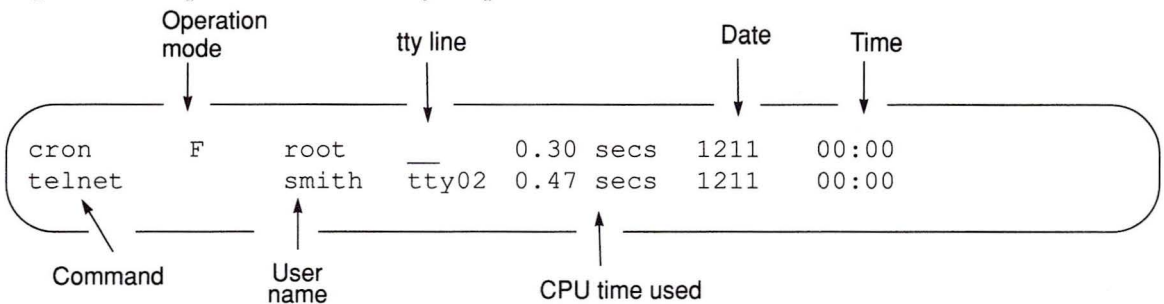

The output of Figure 28 contains the following fields from left to right:

- Command name of the process
- Modes of operation. This could be any of the following values:
 - S Command executed with superuser privileges
 - F Command ran after a fork without a following exec
 - D Command terminated with generation of a core file
 - X Command terminated with a signal
 - f Command ran as a fixed-schedule job at least part of the time
- User name
- tty line
- CPU time used

Summarizing login and logout data

Login, logout, and reboot data are logged in the `/usr/adm/wtmp` file, and bill execution data is logged in the `/usr/adm/bill-acct` file. Both files are binary files. The `connecttime` utility translates the information in these binary files into an ASCII text file that contains when, on which device, and by whom logins, logouts, executions, and termination of bill occur. The `connecttime` command format is:

```
connecttime
```

Figure 29 illustrates sample output from this command.

Figure 29 Sample `connecttime` utility output

started	513987521	console	125	159	17000	
terminated	513987521	console				
started	513986436	ttyp2	125	159	0	(convex-ex)
terminated	513986436	tty06				

Labels below the table with arrows pointing to the corresponding fields:

- Event (points to the first column)
- Time executed (points to the second column)
- tty (points to the third column)
- UID (points to the fourth column)
- GID (points to the fifth column)
- Activity (points to the sixth column)
- Remote machine (points to the seventh column)

The most recent entry appears first. The output contains the following fields from left to right:

- Whether the connection started or terminated
- Starting or ending time in seconds
- tty line
- User ID
- Group ID
- Activity ID
- Remote machine from which the user logged in, if login is from remote machine.

You can use the `connecttime.awk` script to summarize this data. For example, enter the following command to pipe the output from the `connecttime` utility through the `connecttime.awk` script:

```
% connecttime | awk -f /usr/adm/sumscripts/connecttime.awk
```

Figure 30 illustrates sample output from this command.

Figure 30 Sample connecttime.awk output

513017451	13569	125	159	17000	tty07	.
513017447	4	125	159	0	tty07	
513015204	1548	77	67	0	ttyp1	(convex-ex)

↑ Starting time ↑ Amount of time connected ↑ UID ↑ GID ↑ Activity ID ↑ tty ↑ Remote machine

The output contains the following fields, from left to right:

- Starting time measured in seconds elapsed since 00:00:00 GMT, January 1, 1970
- Time connected in seconds
- User ID (-1 if user is not in /etc/passwd file)
- Group ID
- Activity ID
- tty line
- Remote machine from which the user logged in

You can optionally run the output of the `connecttime.awk` script through the general summary awk scripts:

- The `genbyact.awk` script summarizes accounting data by activity.
- The `genbygrp.awk` script summarizes accounting data by group.
- The `genbygrpact.awk` script summarizes accounting data by group and activity pair.
- The `genbyusr.awk` script summarizes accounting data by user.

For example, to pipe the output of the `connecttime.awk` script through the `genbygrpact.awk` script and send it to a file called `connect.rep` in `/tmp`, enter:

```
% connecttime | awk -f /usr/adm/sumscripts/connecttime.awk | \
awk -f /usr/adm/sumscripts/genbygrpact.awk > /tmp/connect.rep
```

If you do not specify an output file, results are displayed on the terminal screen.

Summarizing tape use data

Tape use data is logged in the `/usr/adm/tp-acct` file. This file is a text file and can be viewed using the `cat`, `less`, or `more` utilities. Figure 31 illustrates a sample `tp-acct` file.

Figure 31 Sample `/usr/adm/tp-acct` file

allocated	507507897	/dev/rmt16	311	49	0	mt:0
deallocated	507507923		311	49	0	mt:0
allocated	507568225	/dev/rmt20	0	58	0	mt:1

↑ Event	↑ Time of event	↑ Tape device	↑ UID	↑ GID	↑ Activity	↑ Unit #
------------	--------------------	------------------	----------	----------	---------------	-------------

This file contains the following fields, from left to right:

- Whether tape drive was allocated or deallocated
- Time tape drive was mounted or unmounted
- Tape device
- User ID
- Group ID
- Activity ID
- Tape device unit number

You can optionally run the data in the `/usr/adm/tp-acct` file through the `tape.awk` script. This script converts data in the `/usr/adm/tp-acct` file to a format that can be processed by the general summary `awk` scripts. Enter the following command to do this:

```
% awk -f /usr/adm/sumscripts/tape.awk /usr/adm/tp-acct > tape.rep
```

If you do not enter an output file name, results display on the terminal screen. The output in this example is saved to the file `tape.rep`. Figure 32 illustrates the output for the `tape.awk` command.

Figure 32 Sample `tape.awk` output

51276300	8	0	60	60100	unit1
512768993	100	0	60	60100	unit0
512770017	2	0	60	60100	unit1

↑ Starting time ↑ Seconds used ↑ UID ↑ GID ↑ Activity ID ↑ Tape drive

The output contains the following fields, from left to right:

- Starting time, measured in seconds elapsed since 00:00:00 GMT, January 1, 1970
- Amount of time in seconds tape drive was allocated
- User ID
- Group ID
- Activity ID
- Logical name of tape drive

You can optionally pipe the output of the `tape.awk` script through the general summary `awk` scripts:

- The `genbyact.awk` script summarizes accounting data by activity.
- The `genbygrp.awk` script summarizes accounting data by group.
- The `genbygrpact.awk` script summarizes accounting data by group and activity pair.
- The `genbyusr.awk` script summarizes accounting data by user.

For example, to pipe the output of the `tape.awk` script through the `genbygrpact.awk` script and send it to a file called `tape.rep` in `/tmp`, enter the following command:

```
% awk -f /usr/adm/sumscripts/tape.awk /usr/adm/tp-acct | awk -f \
/usr/adm/sumscripts/genbygrpact.awk > /tmp/tape.rep
```

If you do not specify an output file, the results are displayed on the terminal screen.

Summarizing printer use data

Printer use data is logged in the `/usr/adm/lpd-acct` file. This file is an ASCII file and can be viewed using the `cat`, `less`, or `more` utilities. Figure 33 illustrates a sample `lpd-acct` file.

Figure 33 Sample `lpd_acct` file

51276300	2	293	60	0	lp	smith	louie
512768993	16	268	55	520	lp	jones	dewey
512770017	2	0	0	0	lp	root	louie

↑	↑	↑	↑	↑	↑	↑	↑
Starting time	Pages printed	UID	GID	Activity ID	Device	User name	Machine name

This file contains the following fields, from left to right:

- Time printer was used
- Number of pages printed
- User ID
- Group ID
- Activity ID
- Device used
- User name
- Machine name

You can optionally process the printer accounting data in the `/usr/adm/lpd-acct` file with the `pac` summarizing utility or the general summary `awk` scripts.

Using the `pac` summarizing utility

Enter the following command to process the printer accounting data using the `pac` utility:

```
% pac
```

The output is sorted alphabetically by user, but this can be controlled by specifying different options. Some of the more common options are listed below. See the `pac(8)` man page for details on other available options.

- `c` Sort the output by cost.
- `r` Reverse the order of the output.
- `s` Place summary data in `/usr/adm/lpd-acct_sum`.

Figure 34 shows sample `pac` output.

Figure 34 Sample `pac` utility output

USER	PAGES	RUNSCOST (\$)	(in dollars)
smith	23	8	0.46
jones	11	2	0.22
brown	253	34	5.06
TOTAL	287	44	5.74

↑ User name ↑ Pages printed ↑ Number of print jobs ↑ Cost of printing

This output contains the following fields, from left to right:

- User name
- Number of pages printed
- Number of print jobs executed
- Total cost for printing

The cost is arbitrary. See the `pac(8)` man page for the details on how to modify the cost equation.

Using general summary scripts

You can optionally process the data in the `/usr/adm/lpd-acct` file through the general summary `awk` scripts. This is the recommended method.

- The `genbyact.awk` script summarizes accounting data by activity.
- The `genbygrp.awk` script summarizes accounting data by group.
- The `genbygrpact.awk` script summarizes accounting data by group and activity pair.
- The `genbyusr.awk` script summarizes accounting data by user.

For example, to process printer use data through the `genbygrp.awk` script and send it to a file called `printer.rep` in `/tmp`, enter:

```
% awk -f /usr/adm/sumscripts/genbygrp.awk /usr/adm/lpd-acct > \  
/tmp/printer.rep
```

If you do not specify an output file, the results are displayed on the terminal screen.

Summarizing disk use data

Disk use accounting data is run through a combination of standard utilities, shell scripts, and `awk` scripts. The main disk use utility is `diskuse`. This utility displays disk usage in kbytes for a directory by user and group. To override directory protections, log in as superuser to run `diskuse`. The `diskuse` command format is shown below:

```
diskuse [-d directory]
```

The top of the directory hierarchy is the default. You can specify an alternate directory using the `-d` argument. Figure 35 illustrates sample `diskuse` utility output.

Figure 35 Sample `diskuse` utility output

```

.....users
      35 smith
      15 jones
.....groups
      50 project1
  
```

↑
kilobytes used

The `diskmerge.awk` script merges two versions of `diskuse` output to create totals for each user and group. You can use the `diskmerge.awk` script to keep track of disk use over a period of time by adding current usage data to old data. For example, yesterday you stored `diskuse` totals in a file called `diskuse.out`. Today, you want to merge `diskuse` totals with yesterday's to get a two-day total. To do this, enter:

```
% diskuse | cat - diskuse.out | awk -f /usr/adm/sumscripts/diskmerge.awk
```

Output for this command is the same as that shown in Figure 35.

Output from the `diskuse` utility is in a form suitable for processing through `diskbygrp.awk` and `diskbyusr.awk` scripts.

The `diskbygrp.awk` script summarizes disk use by group. To summarize `diskuse` data from the `/mnt` directory by group, enter:

```
% diskuse -d /mnt | awk -f /usr/adm/sumscripts/diskbygrp.awk > \
diskuse.rep
```

If you do not specify an output file, results are displayed on the terminal screen. Figure 36 illustrates the output from this command.

Figure 36 Sample `diskbygrp.awk` output

The diagram shows a rounded rectangular box containing three lines of text. The first line is "44 zero", the second is "8 mktg", and the third is "520 design". Below the box, two arrows point upwards. The first arrow, labeled "Kilobytes used", points to the "44", "8", and "520" values. The second arrow, labeled "Group name", points to the "zero", "mktg", and "design" values.

44	zero
8	mktg
520	design

This output contains the following fields, from left to right:

- Total disk space used in kilobytes
- Group name

The `diskbyusr.awk` script summarizes disk use by users. To summarize `diskuse` data from the `/mnt` directory by user, enter:

```
% diskuse -d /mnt | awk -f /usr/adm/sumscripts/diskbyusr.awk > \
diskuse.rep
```

If you do not specify an output file, results are displayed on the terminal screen. Figure 37 illustrates the output from this command.

Figure 37 Sample `diskbyusr.awk` output

The diagram shows a rounded rectangular box containing three lines of text. The first line is "44 smith", the second is "8 jones", and the third is "520 brown". Below the box, two arrows point upwards. The first arrow, labeled "Kilobytes used", points to the "44", "8", and "520" values. The second arrow, labeled "User name", points to the "smith", "jones", and "brown" values.

44	smith
8	jones
520	brown

This output contains the following fields, from left to right:

- Total disk space used in kilobytes
- User name

Miscellaneous utilities

The `sort` and `idtoname` utilities are helpful for summarizing accounting information. You can pipe output from general summary scripts through `sort`, then through `idtoname` to get summarized, sorted, and readable results. The `idtoname` utility converts user, group, and activity IDs, as well as any time stamps to user name, group name, activity name, and date respectively.

For example, Figure 38 illustrates a sample of the output you would receive if you run the `/usr/adm/lpd-acct` file through the general `genbygrpact.awk` script.

Figure 38 Sample `genbygrpact.awk` output

0	0	29.000
55	0	6.000
159	10200	64.00

↑
↑
↑
 GID Activity ID Number of pages printed

To display output in order of most number of pages printed, pipe the output through `sort`. For example:

```
% awk -f /usr/adm/sumscripts/genbygrpact.awk /usr/adm/lpd-acct | \
sort +2nr
```

The number 2 indicates the number of fields to skip, `n` is the type of data in the field being sorted (numeric), and `r` specifies sorting in descending order. This command sorts output from `genbygrpact.awk` in reverse order based on the third field in each line. Figure 39 illustrates the output you would get from this command. Compare this to the output you received from the same file in Figure 38.

Figure 39 Sample sorted `genbygrpact.awk` output

159	10200	64.000
0	0	29.000
55	0	6.00

↑
↑
↑
 GID Activity ID Number of pages printed

To display output by group and activity name rather than user and activity IDs, pipe the output through the `idtoname`. For example:

```
% awk -f /usr/adm/sumscripts/genbygrpact. awk /usr/adm/lpd-acct \
| /usr/bin/sort +2nr | /usr/convex/idtoname -gae
```

The `g` option specifies that the first field is a group ID, the `a` option specifies the second field is an activity ID, and the `e` option specifies to echo the third field as it exists. Figure 40 illustrates the output you would get from this command. Compare this to the output you received from the same file in Figure 40.

Figure 40 Sample sorted and `idtoname` `genbygrpact.awk` output

swtst	admin	64.000
project1	misc	29.000
project2	misc	6.00

The diagram shows a rounded rectangular box containing the output of the command. Below the box, three labels with arrows point to the corresponding columns: 'GID' points to the first column, 'Activity' points to the second column, and 'Number of pages printed' points to the third column.

This chapter provides information for managing `sendmail`, the internetwork mail routing program. The major tasks covered are:

- Starting and stopping `sendmail`
- Managing the mail queue
- Load limiting
- Rebuilding the aliases database
- Maintaining the log file
- Debugging `sendmail`

For information on configuring `sendmail`, refer to Chapter 10, “Setting up `sendmail`,” on page 197 in *Managing ConvexOS: Configuration Guide*.

Starting and stopping sendmail

sendmail is usually started in the `/etc/rc.std` file when the system reboots. There are also times, such as when restarting the sendmail daemon, that you start sendmail from the command line.

This section explains how to run the sendmail daemon and freeze the configuration file for quicker sendmail start up. Refer to the sendmail(8) man page for a complete listing of sendmail operating modes and options.

Running the sendmail daemon

sendmail is run in daemon mode by specifying the `-bd` flag. The sendmail daemon must be running to:

- Receive incoming mail over an IPC connection
- Process the mail queue

The sendmail daemon listens for SMTP connection requests on port 25 and forks SMTP servers to accept the connections. When run in this mode, sendmail alters its name as seen by `ps` to show what task it is performing. The most common names are:

- accepting connections
- rejecting connections: load average *<average>*
- running queue
- `svrsmtp <hostname>`

When sendmail is run with the `-qinterval` flag, the queue processing daemon wakes up at the specified interval to process the mail queue. Valid values for the time interval are shown in Table 1.

Table 1 Time interval values

Value	Meaning
s	Seconds
m	Minutes
h	Hours
d	Days
w	Weeks

You can run multiple queue processing daemons simultaneously by using *qinterval*, but you can run only one `sendmail` daemon at a time in `-bd` mode.

The `/etc/rc.std` file starts the `sendmail` daemon at boot time to perform both tasks with the command:

```
# /usr/lib/sendmail -bd -qlh
```

The `-bd` mode enables the `sendmail` daemon to receive mail from the network. The `-qlh` flag instructs `sendmail` to process the mail queue every hour.

If you change the `sendmail` configuration file, you should kill and restart the `sendmail` daemon as explained in Step 2 and Step 3 of the section, “Freezing the configuration,” on page 80.

Freezing the configuration

Each time you start `sendmail`, it reads and interprets the configuration file `/usr/lib/sendmail.cf`. To decrease the time `sendmail` takes to read the file, you can freeze the configuration.

Freezing the configuration creates the file `/usr/lib/sendmail.fc` (fc is for “frozen configuration”). This file is an image of `sendmail`’s data space after reading in the configuration file. If this file exists and is newer than the `sendmail.cf` file, `sendmail` uses the `sendmail.fc` file instead.

To freeze the configuration file:

Step 1 Enter the following command as root:

```
# /usr/lib/sendmail -bz
```

Step 2 Kill the `sendmail` daemon by finding the PID of the `sendmail` process called `accepting connections` and kill the process using the `kill` command as shown in Figure 41. Do not use `kill -9` to kill `sendmail`; this could corrupt the aliases database. Issue the `kill` command without the first argument to send signal 15 to the process.

Figure 41 Killing the `sendmail` daemon

```
# ps aux | grep accepting
root 218 0.0 0.0 456 4 ? I 0:03 -accepting connections
# kill 218
#
```

Step 3 Restart the `sendmail` daemon by entering:

```
# /usr/lib/sendmail -bd -q1h
```

The frozen configuration file must be up-to-date with any changes to the `sendmail` configuration file or other changes that affect `sendmail` operation. Refreeze the configuration file and kill and restart the `sendmail` daemon when any of the following changes:

- The `/usr/lib/sendmail.cf` file
- The contents of a file that defines a file class in the configuration file
- The local UUCP configuration
- The local host name
- `named`’s execution state (running or not running)

Restarting sendmail with a new configuration file

Before making changes to the `sendmail.cf` file, you should first make a copy of the file and name it something similar to `sendmail.cf.new`. Then use the following procedure to replace the old configuration file with the new one:

- Step 1** Test the changes by entering:
- ```
cd /usr/lib
sendmail -bt -Csendmail.cf.new
```
- (Refer to the section, "Debugging sendmail," on page 91, for more information.)
- Step 2** Make a copy of the existing configuration file:
- ```
# cp sendmail.cf sendmail.cf.MMDDYY
```
- MMDDYY* is the date the old configuration file was last modified.
- Step 3** Rename the new configuration file:
- ```
cp sendmail.cf.new sendmail.cf
```
- Step 4** Freeze the configuration file and kill and restart the `sendmail` daemon as explained in the section, "Freezing the configuration," on page 80.

---

## Managing the mail queue

Messages that are temporarily undeliverable are saved in a mail queue for later delivery. For example, if a message going out to a remote SMTP server is not delivered because the server is not running on the remote host, the message envelope, header, and body are stored in the queue. By default, the queue is located in the `/usr/spool/mqueue` directory.

`sendmail` processes the queue by first creating and sorting a list of the queued messages. It then attempts to deliver each message in order. Each message is locked before being processed to prevent other queue processing daemons that may be running from processing it. If a queue processing daemon discovers a locked message, it skips to the next message in its list. Attempts to process locked messages are recorded in the system log if the logging level is 6 or higher.

Messages that are in the queue longer than the time specified by the `T` configuration option are returned to the sender. The default queue timeout is three days. Refer to Chapter 10, "Setting up sendmail," on page 197 in *Managing ConvexOS: Configuration Guide*, and to the `sendmail.cf(5)` man page for more information on configuration options.

---

## Queue priority

A message is assigned an initial priority value based on message size (in bytes), precedence, and number of recipients. The priority value and time the message was created determine the message's place in the queue. A high priority value means the message is processed later in the queue. Large messages and messages with many recipients are given a higher priority value (lower priority) than smaller messages and messages with fewer recipients.

Users can increase the priority of their messages by including a `Precedence:` field in the message header. The value of this field is specified by the `P` lines in the configuration file.

The initial priority value is calculated as

$$\text{priority} = \text{size} - (\text{precedence} \times z) + (\text{recipients} \times y)$$

The weight given to the number of recipients is multiplied by the value specified with the `y` option in the configuration file. The message precedence factor is set with the `z` option in the configuration file. Default values for the `y` and `z` options are 1000 and 1800, respectively.

The priority of a queued message is adjusted each time it is processed based on the value specified by the `Z` configuration option. This value is added to the priority value to penalize queued messages that are undeliverable for long periods of time. The default value for the `Z` option is 9000.

---

## Printing the queue

You can print the contents of the mail queue with the command

```
% /usr/lib/sendmail -bp
```

or

```
% mailq
```

This produces a listing of the queue IDs, the message size, the date the message entered the queue, and the sender and recipients. If you run `sendmail` or `mailq` with the `-v` flag, the output also includes the message priority. Refer to the `mqueue(5)` man page for information on queue file contents and format.

Figure 42 shows an example of output of the `mailq` command.

**Figure 42** Mail queue contents

```
Mail Queue (2 requests)
--QID----Size-----Q-Time-----Sender/Recipient-----
AA13731 5152 Tue Aug 6 16:15 jsmith
 mjones
AA13737 9092 Tue Aug 6 16:16 peters
 dlyons
```

---

## Forcing the queue

`sendmail` is usually started in the `/etc/rc.std` file with the option to process the queue, or redeliver queued messages, at the specified time interval. (Refer to the section, "Running the `sendmail` daemon," on page 78.) However, if the queue becomes clogged, you can force `sendmail` to process the queue immediately by invoking `sendmail` with the `-q` flag and no specified interval.

---

## Load limiting

There are two `sendmail` configuration options you can use to limit load averages on your system: the `x` and `X` options.

If the load average on your system gets too high, you can use the `x` option to have `sendmail` queue low priority messages rather than deliver them. When the five-minute load average exceeds the value of the `x` option, `sendmail` queues messages if the queue factor (set with the `q` option), divided by the difference in the current load average and the load average limit plus one, exceeds the priority of the message.

That is, if the load average is greater than the load average limit (`x`), the message is queued if the priority value is greater than

$$\text{queue factor} / (\text{load average} - \text{load average limit} + 1)$$

This means that when the load average reaches the load average limit, the `q` option defines the minimum priority value (maximum priority) of messages that are queued. The default value of the `q` option is 10000. The value of the `x` option is set to 8 in the supplied configuration file.

The `X` option defines a load average at which `sendmail` refuses to accept network connections. Locally generated mail, including incoming UUCP mail, is still accepted.

Refer to Chapter 10, “Setting up sendmail,” on page 197 in *Managing ConvexOS: Configuration Guide*, for information on setting configuration options.

Table 2 lists recommended values for the x and X options for various CONVEX systems. These values depend on site configuration, the applications that are running, and the importance of prompt mail delivery at your site.

**Table 2** Recommended x and X option values

| Hardware   | Mail is low priority |      | Mail is high priority (deliver on a heavily loaded schedule) |      |
|------------|----------------------|------|--------------------------------------------------------------|------|
|            | x                    | X    | x                                                            | X    |
| C1         | x=4                  | X=8  | x=8                                                          | X=12 |
| C210/C3210 | x=6                  | X=10 | x=10                                                         | X=14 |
| C220/C3220 | x=8                  | X=12 | x=12                                                         | X=16 |
| C230/C3230 | x=10                 | X=14 | x=14                                                         | X=18 |
| C240/C3240 | x=12                 | X=16 | x=16                                                         | X=20 |
| C3410      | x=6                  | X=10 | x=10                                                         | X=14 |
| C3420      | x=8                  | X=12 | x=12                                                         | X=16 |
| C3430      | x=10                 | X=14 | x=14                                                         | X=18 |
| C3440      | x=11                 | X=16 | x=16                                                         | X=20 |
| C3810      | x=10                 | X=18 | x=16                                                         | X=22 |
| C3820      | x=12                 | X=20 | x=20                                                         | X=24 |
| C3830      | x=14                 | X=22 | x=22                                                         | X=26 |
| C3840      | x=16                 | X=24 | x=22                                                         | X=28 |
| C3850      | x=18                 | X=26 | x=24                                                         | X=30 |
| C3860      | x=20                 | X=28 | x=26                                                         | X=32 |
| C3870      | x=22                 | X=30 | x=28                                                         | X=34 |
| C3880      | x=24                 | X=32 | x=30                                                         | X=38 |

## Rebuilding the aliases database

The aliases database exists in two formats: a text format, located in the file `/usr/lib/aliases`, and a dbm format, located in the files `/usr/lib/aliases.dir` and `/usr/lib/aliases.pag`. (Refer to Chapter 10, "Setting up sendmail," on page 197 in *Managing ConvexOS: Configuration Guide*, for information on creating the aliases database.)

The dbm format of the database must be rebuilt to reflect any changes to the aliases text file. If the `D` option is specified in the configuration file, the database is updated automatically if the dbm format is mode 666, or if `sendmail` is running `setuid` to root.

If your aliases database (both the text and dbm versions) is not world writable or you do not run `sendmail` `setuid` to root, you must rebuild the aliases database manually. To rebuild the aliases database, enter the command:

```
/usr/ucb/newaliases
```

This command is equivalent to invoking `sendmail` with the `-bi` flag:

```
/usr/lib/sendmail -bi
```

Problems can result if a `sendmail` process accesses the dbm version while it is only partially built. The circumstances under which this can happen are:

- A process accesses the database while another is rebuilding it.
- The process rebuilding the database dies (due to being killed or a system crash) before completing the rebuild.

To avoid this problem, `sendmail` ignores interrupts while rebuilding the database. This prevents someone from aborting the process and leaving a partially rebuilt database. In addition, `sendmail` adds an alias of the form

```
@: @
```

at the end of the build if the `a` configuration option is set. Before accessing the database, `sendmail` waits the amount of time specified by the `a` option to check for the presence of this entry. If the entry is missing, `sendmail` rebuilds the database automatically if the `D` option is specified in the configuration file, or issues a warning message and continues.

---

## Maintaining the log file

sendmail maintains a log of its activities in the file `/usr/spool/mqueue/syslog`. Logging in sendmail is supported by the `syslogd` daemon.

---

### Log levels

sendmail logs:

- System failures and configuration errors (SYSERR)
- Administrative activities, such as rebuilding the aliases database or killing and restarting the sendmail daemon
- Events associated with mail transactions

Logging is performed based on the level of an event. At the lowest level, only unusual situations are recorded. Logging at higher levels records normal activities. Log levels under 10 are considered useful; levels 10 and above are normally used for debugging.

You can set the logging level in the sendmail configuration file with the `L` option. The logging level can also be set on the command line with the `-L` option to specify the default level or with the `-Ln` option, where `n` is logging level. The default logging level is 9.

Table 3 lists the sendmail log levels and the type of information logged at each level.

**Table 3** sendmail log levels

| Level | Information logged                                                             |
|-------|--------------------------------------------------------------------------------|
| 0     | No logging.                                                                    |
| 1     | Major problems only.                                                           |
| 2     | Message collections and failed deliveries                                      |
| 3     | Successful deliveries.                                                         |
| 4     | Messages that are deferred (due to a host being down, etc.)                    |
| 5     | Normal queueing of messages.                                                   |
| 6     | Unusual but benign incidents, such as attempts to process a locked queue file. |
| 7     | Information related to the aliases database.                                   |

**Table 3** sendmail log levels (continued)

| <b>Level</b> | <b>Information logged</b>                                                                                                       |
|--------------|---------------------------------------------------------------------------------------------------------------------------------|
| 8            | Additional information related to the aliases database.                                                                         |
| 9            | Internal queue ID to external message ID mapping. This can be useful for tracing a message as it travels between several hosts. |
| 11           | Messages about envelope handling.                                                                                               |
| 12           | Several messages useful for debugging.                                                                                          |
| 16           | Verbose information about the queue.                                                                                            |
| 20           | Verbose information about file opening, closing, and other miscellaneous information.                                           |

---

## Log file format

Each line in the log file contains a time stamp, the name of the machine that generated it, the word "sendmail:" followed by the PID, and a message. Figure 43 shows an example of mail transaction log entries with the logging level set to 9.

**Figure 43** Log file entries

```
Sep 4 12:49:50 host1 sendmail[19839]: AA19839: message-id=
<9109041749.AA19839@host1.cvx.com>
Sep 4 12:49:50 host1 sendmail[19839]: AA19839: from=elton, size=451,
class=0, received from local
Sep 4 12:49:52 host1 sendmail[19841]: AA19839:
to=cascio@host2.cvx.com, delay=00:00:03, stat=Sent
```

Each log entry for a mail transaction has a queue ID associated with it. In Figure 43, the queue ID is AA19839. All log entries for the same input message have the same queue ID. The following additional information is logged for each delivery:

|             |                                                                                                                                                                                                                  |
|-------------|------------------------------------------------------------------------------------------------------------------------------------------------------------------------------------------------------------------|
| message-id= | If a message had a Message-Id header line when it was input to <code>sendmail</code> , this is included in the logged information. The unique message ID can be used to trace a message through mail relays.     |
| from=       | Message sender, followed by message size, class, and system from which the message was received.                                                                                                                 |
| to=         | Message recipient. Multiple recipients on the same host can appear on the same line. Multiple recipients on different hosts are recorded on separate lines. Delivery status (sent, failed, or queued) is logged. |

---

## Debugging sendmail

If you experience difficulties with `sendmail`, such as bounced mail, first verify that:

- The frozen configuration file is up-to-date with any recent changes to:
  - The `sendmail.cf` file
  - Files from which file classes are generated
  - Local host name
  - Name server configuration
  - Local UUCP configuration

Refer to the section, “Freezing the configuration,” on page 80.

- The aliases database is up-to-date with any recent changes to the aliases text file. Refer to the section, “Rebuilding the aliases database,” on page 87.

The next steps in debugging addressing or configuration problems are:

- Check the rulesets with `sendmail -bt`
- Check aliases with `sendmail -bv`
- Check connections with `/usr/ucb/mail -v`

These procedures, along with general debugging information, are described in the section, “Testing the configuration,” in Chapter 10, “Setting up sendmail,” on page 197 of *Managing ConvexOS: Configuration Guide*.



---

# Checking the file system

# 8

Maintaining file system integrity is one of the most critical functions of a system manager. File systems can easily become corrupted if inconsistencies are not caught and corrected in time. This chapter presents an overview of the ConvexOS file system and describes how to use the file system check (`fsck`) utility to find and correct file system problems.

---

## Internal view of the file system

The ConvexOS file system controls access to data files as well as devices on the system. It provides a hierarchical organization for files and directories, buffering of data, and control of file access. Before describing how `fsck` repairs the file system, knowing the internal organization of the ConvexOS file system is useful. The following sections give a brief overview of relevant information.

For information about creating file systems, refer to Chapter 4, "Setting up the disk system," in the *Configuration Guide*.

---

### The superblock

A file system is described by its *superblock*. The superblock is built when the file system is created (with `newfs` or `newst`) and never changes. It contains the basic parameters of the file system, such as the number of data blocks in the file system and a count of the maximum number of files. Because the superblock contains critical data, `newfs` replicates it across the disk partition to protect against catastrophic loss. The default superblock always resides at a fixed offset from the beginning of the partition. Redundant superblocks are not used unless a head crash or some other disk error corrupts the default superblock.

---

### Summary information

Nonreplicated summary information is associated with the superblock. The summary information, which changes as the file system is modified, contains the number of blocks, fragments, inodes, and directories in the file system.

---

### Data blocks

A file system is divided into units called data blocks or, simply, blocks. A block is a contiguous sequence of data. File system data blocks can be 4K, 8K, 16K, 32K, or 64K bytes in size; each character in a file is represented by a byte of information. A file may reside in many blocks located on different portions of the disk. Ideally, blocks that form a file should be contiguous to optimize disk performance. However, as the disk is used and files are deleted, free blocks become increasingly scattered. To handle this, the file system uses inodes to point to noncontiguous blocks associated with a file.

## Inodes

Every file in the file system has an associated descriptor called an index node, or *inode*. An inode contains information describing ownership of the file, time stamps indicating modification and access times for the file, and an array of indexes pointing to the data blocks for the file. Figure 44 shows the structure of an inode.

Figure 44 Inode structure

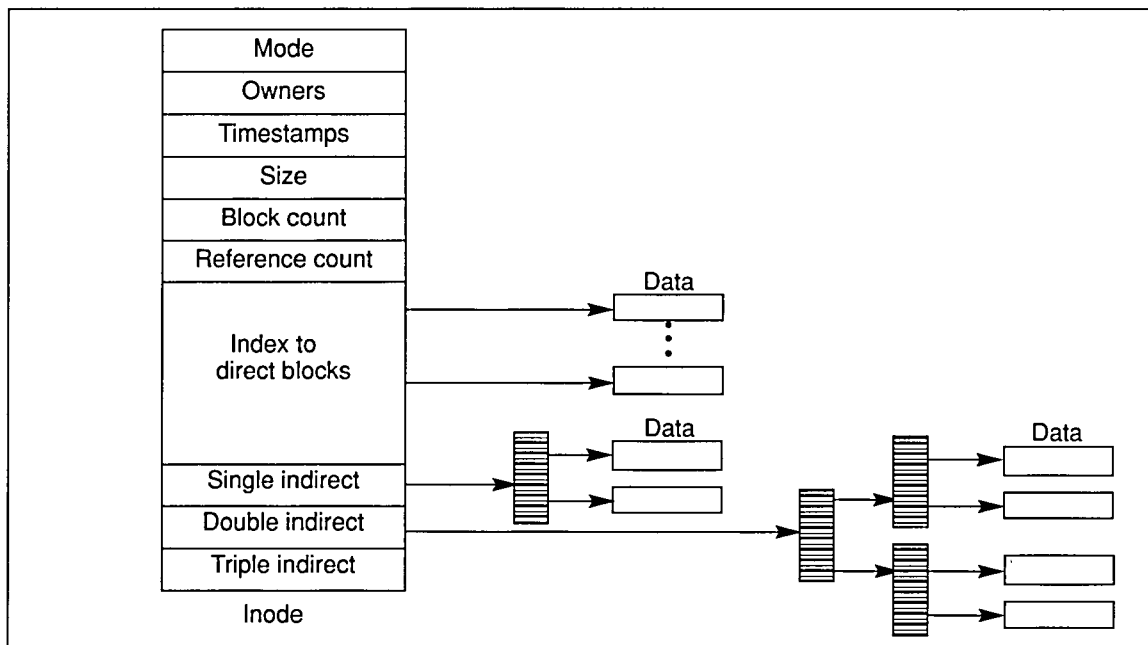

The first 12 blocks of a file are directly referenced by values stored in the inode structure itself. Additional data blocks are described with a pointer from the inode to an indirect data block as shown in Figure 44. When accessing a file over 12 blocks long, the system must first fetch the indirect block, which stores the number of the data block.

An indirect block that contains data block numbers is called a single indirect block; an indirect block that contains block numbers of single indirect blocks is called a double indirect block. In a file system with a 4096-byte block size, a single indirect block contains 1024 more block addresses, a double indirect block contains 1024 addresses of single indirect blocks, and a triple indirect block contains 1024 addresses of double indirect blocks.

To create files up to  $2^{31}$  bytes using only two levels of indirection, the minimum size of a file system block is 4096 bytes. The size of file system blocks can be any power of two greater than or equal to 4096. The block size of the file system is maintained in the superblock, so it is possible for file systems of different block sizes to be accessible simultaneously on the same system. The block size must be decided when `newfs` creates the file system; it cannot be changed subsequently without rebuilding the file system.

---

## Cylinder groups

The file system partitions a disk into one or more areas called cylinder groups. A cylinder group is made up of one or more consecutive cylinders on a disk. Figure 45 illustrates the layout of cylinder groups on a disk in the ConvexOS file system.

**Figure 45** Layout of cylinder groups

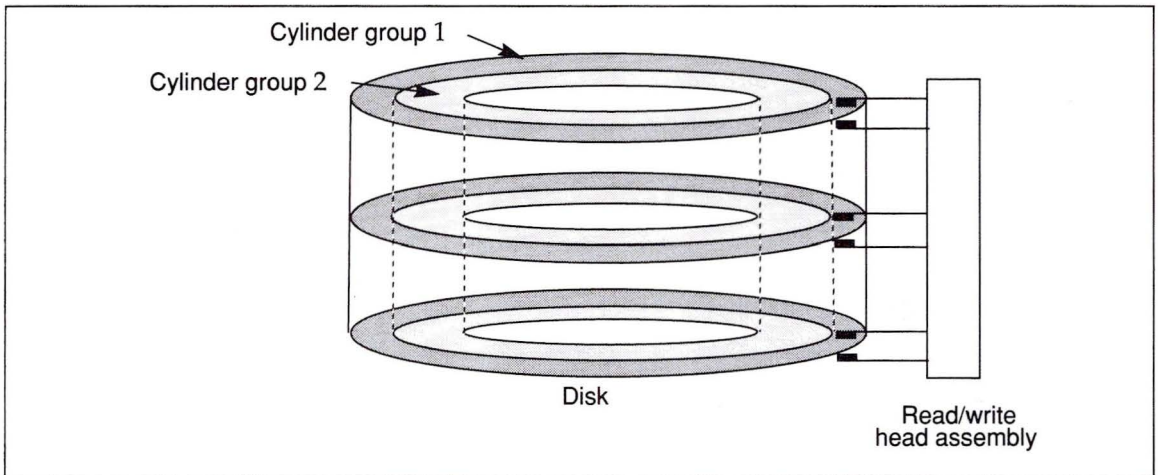

Each cylinder group includes inode slots for files, a block map describing available blocks in the cylinder group, and summary information describing usage of data blocks within the cylinder group. A fixed number of inodes is allocated for each cylinder group when the file system is created. Typically, one inode is allocated for each 2048 bytes of disk space; this is usually many more inodes than is ever needed.

---

## Fragments

To avoid file system waste when storing small files, the file system space allocator divides a single file system block into one or more fragments. The fragmentation of the file system is specified when the file system is created; each file system block can be broken into 1, 2, 4, or 8 addressable fragments. The smallest fragment size is constrained by the disk sector size which is, typically, 512 bytes (2 kbytes for IDC disks). The block map associated with each cylinder group records the space availability at the fragment level. Aligned fragments are examined to determine block availability.

On a file system with a block size of 4096 bytes and a fragment size of 1024 bytes, a file is represented by zero or more 4096-byte blocks of data, and possibly a single fragmented block. If a block must be fragmented to obtain space for a small amount of data, the remainder of the block is made available to other files. For example, consider an 11,000-byte file stored on a file system with a 4096-byte block size and a 1024-byte fragment size. This file uses two full-size blocks and a 3072-byte fragment. If no fragments with at least 3072 bytes are available when the file is created, a full-size block is split providing the 3072-byte fragment and an unused 1024-byte fragment. This remaining fragment can be allocated to another file as needed.

---

## How file system inconsistencies occur

As you create and modify files, the file system tracks inode allocation, the number of blocks in each file, and the total number of free blocks and inodes. This information is maintained in memory until the disks are updated by the sync or update commands, or the sync system call. Unfortunately, not all information regarding a file is written to disk at the same time. For example, the system may update the inode and write the data blocks for a given file to disk, but not update the superblock until later. If the system crashes or is corrupted during this time, the file system will not be consistent because information left in memory was not written to disk before the crash occurred.

---

### Caution

---

**A crash is not the only cause of file system corruption. Hardware failures, improper shutdown procedures, or operator errors such as taking a disk offline without unmounting file systems or write-protecting a mounted file system can also cause file systems to become corrupted. If inconsistencies are found but not corrected, the file system may become so severely corrupted that it is not repairable.**

---

## File system information checked

---

### Note

---

Inconsistencies in the file system can occur in a number of areas. The following sections describe what can go wrong in a file system and how `fsck` finds inconsistencies.

The `fsck` utility is usually run noninteractively. In this mode, it only fixes corruptions that you would normally expect from an improper system shutdown. However, for the remainder of this chapter, `fsck` is described from the interactive standpoint.

---

## Checking the superblock

The most commonly corrupted item in a file system is the summary information associated with the superblock. Summary information is prone to corruption because it is modified every time data blocks or inodes are modified.

The superblock is checked for inconsistencies in file system size, number of inodes, free block count, and free inode count. File-system size must be larger than the number of blocks used by the superblock and the number of blocks used by the list of inodes. File-system size and layout information are the most critical pieces of information that `fsck` checks. While there is no way to check these sizes (because they are statically determined by `newfs`), `fsck` can verify that sizes are within reasonable bounds. All other file system checks require that sizes be correct. If `fsck` detects corruption in the static parameters of the default superblock, it requests the location of an alternate superblock.

---

## Free block checking

The `fsck` utility checks that all blocks marked as free in the cylinder-group block maps are not claimed by any files. When all the blocks have been initially accounted for, `fsck` checks that the number of free blocks plus the number of blocks claimed by the inodes equals the total number of blocks in the file system.

If anything is wrong with the block allocation maps, `fsck` rebuilds them, based on the list of allocated blocks it has calculated.

Summary information associated with the superblock counts the total number of free blocks within the file system. `fsck` compares this count to the number of free blocks it found. If the two counts do not agree, `fsck` replaces the incorrect count in the summary information with the actual free-block count.

The summary information also counts the total number of free inodes within the file system. `fsck` compares this count to the number of free inodes it found. If the two counts do not agree, `fsck` replaces the incorrect count in the summary information with the actual free inode count.

---

## Checking the inode state

An individual inode is not as likely to be corrupted as the allocation information. However, because of the great number of active inodes, a few inodes are usually corrupted.

The `fsck` utility sequentially checks the list of inodes in the file system, starting with inode 2 (erased files have their inode number set to 0; inode 1 is reserved for future use). `fsck` progresses through the list until it reaches the last inode in the file system. It checks the state of each inode for inconsistencies in format and type, link count, duplicate blocks, bad blocks, and inode size.

Each inode contains a mode word. This mode word describes the type and allocation state of the inode. Inodes must be one of seven types:

- Regular
- Directory
- Symbolic link
- Block special
- Character special
- Socket
- Named pipe (fifo)

Inodes may have one of three allocation states:

- Unallocated
- Allocated
- Neither unallocated nor allocated

The last state suggests an incorrectly formatted inode. This can occur if bad data is written into the inode list. The only possible corrective action is for `fsck` to clear the inode.

---

## Checking inode links

Each inode contains a count of the total number of directory entries linked to the inode. The `fsck` utility verifies the link count of each inode by starting at the root of the file system, and descending through the directory structure. The actual link count for each inode is calculated during the descent.

If the stored link count is nonzero and the actual link count is zero, there is no directory entry for the inode; `fsck` places the disconnected file in the lost+found directory. If the stored and actual link counts are nonzero and unequal, a directory entry may have been added or removed without the inode being updated. If this happens, `fsck` replaces the incorrect stored link count with the actual link count.

Each inode contains a list, or pointers to lists (indirect blocks), of all the blocks claimed by the inode. Because indirect blocks are owned by an inode, inconsistencies in an indirect block directly affects the inode that owns it.

The `fsck` utility compares each block number claimed by an inode against a list of already allocated blocks. If another inode already claims a block number, the block number is added to a list of duplicate blocks. Otherwise, the list of allocated blocks is updated to include the block number.

If there are duplicate blocks, `fsck` performs a partial second pass over the inode list to find the inode of the duplicated block. The second pass is needed: without examining the files associated with these inodes for correct content, not enough information is available to determine which inode is corrupted and should be cleared. If this condition does arise, the inode with the earliest modification time is usually incorrect, and should be cleared. However, `fsck` prompts you to clear both inodes; you must decide which one to keep and which one to clear.

`fsck` checks the range of each block number claimed by an inode. If the block number is lower than the first data block in the file system, or greater than the last data block, the block number is a bad block number. When an inode has many bad blocks, it is usually caused by an indirect block that was not written to the file system. If an inode contains bad block numbers, `fsck` prompts you to clear it.

---

## Checking inode data size

Each inode contains a count of data blocks it contains. The number of actual data blocks is the sum of allocated data blocks and indirect blocks. `fsck` computes the actual number of data blocks and compares that block count against the number of actual blocks the inode claims. If an inode contains an incorrect count, `fsck` prompts you to fix it.

Each inode contains a 64-bit size field. Size is the number of data bytes in the file associated with the inode. The consistency of the byte size field is roughly checked by computing from the size field the maximum number of blocks that should be associated with the inode, and comparing that expected block count against the actual number of blocks the inode claims.

---

## Checking data associated with an inode

An inode can directly or indirectly reference three kinds of data blocks:

- Plain data blocks contain the information stored in a file.
- Symbolic link data blocks contain the path name stored in a link.
- Directory data blocks contain directory entries. `fsck` can check only the validity of directory data blocks.

All referenced blocks must be the same kind.

Each directory data block is checked for inconsistencies:

- Directory inode numbers pointing to unallocated inodes
- Directory inode numbers greater than the number of inodes in the file system
- Incorrect directory inode numbers for "." and ".."
- Directories that are not attached to the file system

If the inode number in a directory data block references an unallocated inode, `fsck` removes that directory entry.

If a directory entry inode number references outside the inode list, `fsck` removes that directory entry. This condition occurs if bad data is written into a directory data block.

The directory inode number entry for "." must be the first entry in the directory data block. The inode number for "." must reference itself; for example, it must equal the inode number for the directory data block. The directory inode number entry for ".." must be the second entry in the directory data block. Its value must equal the inode number for the parent of the directory entry (or the inode number of the directory data block if the directory is the root directory). If the directory inode numbers are incorrect, `fsck` replaces them with correct values.

---

## Checking file system connectivity

The `fsck` utility checks the general connectivity of the file system. If directories are not linked into the file system, `fsck` links the directory back into the file system by placing it in the `lost+found` directory.

---

## Running `fsck`

The `fsck` utility is a multi-pass file system check program, each pass invoking a different phase of `fsck`. After initialization, `fsck` runs successive phases over each file system, checking blocks and sizes, path names, connectivity, reference counts, and cylinder groups. After the final phase, `fsck` performs cleanup operations and exits.

If you invoke `fsck` without specifying a device name in the command line, it repeats all its phases for all devices. CONVEX recommends that you use `preen` rather than use `fsck` in this manner.

The `fsck` utility is an interactive file system check-and-repair program. It uses redundant structural information in the file system to perform consistency checks. For example, `fsck` compares the number of free blocks to the total number of blocks in the file system, minus the number of blocks in use. If the two numbers are not equal, `fsck` displays an error message. Typically, these inconsistencies result from interruption of file system updates, which are performed every time a file is modified.

The `fsck` utility runs in two modes. In the noninteractive mode, it only makes changes to the file system that will always be correct. This mode is used when the operating system is booting. If an inconsistency is found that `fsck` cannot fix, it exits with a nonzero exit status, leaving the system running in single-user mode. In the interactive mode, `fsck` reports the problem and suggests a corrective action; you must decide whether or not to make the corrections.

With the exception of the root (`/`) file system, unmount a file system to check it. Check the root file system only when the computer is in single-user mode and there is no other activity on the machine.

---

### Note

---

**While in multiuser mode, some file systems will not unmount because daemons are using files in that file system (for example, `/tmp`).**

The format of `fsck` is:

```
fsck -p [file_system]...
```

```
fsck [-b block] [option ...] [file_system]...
```

The first form of `fsck`, `fsck -p`, checks a specified file system or a standard set of file systems as specified in the `/etc/fstab` file. It uses information in this file to inspect groups of disks in parallel, taking advantage of I/O overlap to check file systems as quickly as possible. This form of `fsck` is normally used in the `/etc/rc` script during an automatic reboot. The `preen` utility can also check disks in this fashion. Refer to the section “The `preen` utility” in this chapter for more information.

To speed file system checking, `fsck -p` only checks file systems that have the dirty bit set in the superblock. The bit is set when data has been written to a file system since the last sync to disk.

The second form uses the following options:

- b Use the block specified in *block* as the superblock for the file system. Block 32 is often an alternate superblock.
- c Inode fields unused prior to ConvexOS V9.0 are zeroed.
- d Instructs `fsck` to display diagnostic information while checking file systems.
- f Forces `fsck` to look at all file systems, regardless of the setting of the dirty bit. `fsck` uses `-f` as a default unless `-p` is specified.
- m The mode given to the lost+found directory if `fsck` needs to create it. The default is 01777.
- n Specifies a “no” response to all questions asked by `fsck`. With this option, the file system is not opened for writing.
- y Specifies a “yes” response to all questions asked by `fsck`. Use this option with caution— you are giving `fsck` permission to continue even after encountering unlimited difficulties.

Figure 46 shows a sample `fsck` session.

Figure 46 Sample fsck session

```
% fsck /dev/dd0a
/dev/dd0a
Last Mounted on /
Root file system
**Phase 1 - Check Blocks and Sizes
**Phase 2 - Check Pathnames
**Phase 3 - Check Connectivity
**Phase 4 - Check Reference Counts
**Phase 5 - Check Cyl Groups
3163 files, 34968 frags used, 99639 frags free (263 frags, \
12422 blocks) (8k/1k)
%
```

In the example, *fsck* is run without options, and a message is displayed as each phase is completed. If *fsck* encounters an inconsistency, it displays an error message describing the problem.

At the end of the program, a summary message is displayed showing the number of files (inodes), fragments used, and fragments available.

There are seven file system check phases in *fsck* (phase 1B is usually optional), an initialization phase and a clean-up phase. Each phase is summarized below:

- **Phase 1—Check blocks and sizes**—*fsck* checks the inode list. *fsck* may discover error conditions that result from checking inode types, setting up the zero-link-count table, checking inode block numbers for bad or duplicate blocks, checking inode size, and checking inode format.
- **Phase 1B—Rescan for more DUPS**—*fsck* rescans the file system and searches for the inode that previously claimed a particular block. Phase 1B runs only if duplicate blocks (that is, blocks that belong to multiple inodes) are found.
- **Phase 2—Check pathnames**—*fsck* removes directory entries that point to inodes that have uncorrectable error conditions from Phase 1 and Phase 1B. In Phase 2, *fsck* may discover error conditions that result from root inode mode and status, directory inode pointers out of range, and directory entries pointing to bad inodes.

- **Phase 3—Check connectivity**—`fsck` checks directory connectivity seen in Phase 2. In this phase, `fsck` may discover error conditions that result from unreferenced directories and missing or full lost+found directories.
- **Phase 4—Check reference counts**—`fsck` reports messages that result from unreferenced files; a missing or full lost+found directory; incorrect link counts for files, directories, or special files; unreferenced files and directories; bad or duplicate blocks in files and directories; and incorrect total free inode counts.
- **Phase 5—Check cylinder groups**—`fsck` checks the free-block maps. `fsck` looks for errors resulting from allocated blocks in the free-block maps, free blocks missing from free-block maps, and an incorrect total free-block count.
- **Phase 6—Salvage cylinder groups**—`fsck` reconstructs free-block maps. No error messages are produced.

---

## The preen utility

The `preen` utility runs `fsck` in a highly optimized manner, checking multiple disk partitions simultaneously. It works similarly to `fsck -p`, but uses base names of disks to determine which partitions are on the same physical drive and tries to keep all drives busy.

When a system is booted to multiuser mode from the SPU or directly from `powerup`, `preen` runs automatically on all file systems before entering multiuser mode. If the machine is booted to single-user mode, you must run `preen` manually before entering multiuser mode.

One of the greatest advantages of using `preen` is that system managers no longer need to configure pass numbers in the `/etc/fstab` file.

The command format for `preen` is:

```
preen [-L limit] [fsck_options]
```

Status returned by `preen` matches (as closely as possible) that of `fsck`.

Use the `-L` option to specify the maximum number (*limit*) of disks for which `preen` may run concurrent `fsck` processes. `preen` with no options starts one `fsck` process for each disk drive on your system. For systems with large numbers of disks this default condition could lead to memory swapping, cutting down on the efficiency of the `preen`.

`preen` passes any `fsck` options it is given to the `fsck` processes it starts. Because `preen` passes these options to all `fsck` processes, do not give `preen` the `-b` option.

---

## Error messages

The `fsck` utility can produce error messages during each phase of execution. The remaining sections in this chapter list these messages.

Error messages are categorized by phase and are presented in the following order:

- Initialization phase
- Phase 1
- Phase 1B
- Phase 2
- Phase 3
- Phase 4
- Phase 5
- Phase 6
- Clean-up phase

A brief description is included with each message. Error conditions that can occur in more than one phase are discussed in the initialization phase.

The following abbreviations are used in `fsck` messages:

|       |                             |
|-------|-----------------------------|
| BLK   | Block number                |
| CG    | Cylinder group              |
| DUP   | Duplicate block number      |
| DIR   | Directory name              |
| MTIME | Time file was last modified |
| UNREF | Unreferenced                |

The following single-letter abbreviations are used in `fsck` messages. These abbreviations are replaced by an actual value when the message appears on your screen.

|          |                          |
|----------|--------------------------|
| <i>B</i> | Block number             |
| <i>C</i> | Cylinder group           |
| <i>F</i> | File (or directory) name |
| <i>I</i> | Inode number             |
| <i>M</i> | File mode                |
| <i>N</i> | <code>fsck</code> option |

|          |                                                                                              |
|----------|----------------------------------------------------------------------------------------------|
| <i>O</i> | User ID of a file's owner                                                                    |
| <i>S</i> | File size                                                                                    |
| <i>T</i> | Time file was last modified                                                                  |
| <i>X</i> | Link count; number of BAD, DUP, or MISSING blocks; or number of files (depending on context) |
| <i>Y</i> | Corrected link-count number. Number of blocks in file system (depending on context)          |
| <i>Z</i> | Number of free blocks                                                                        |

---

## Initialization phase

During initialization, tables must be set up and files must be opened. Error conditions in this phase can occur from:

- Command line options
- Memory requests
- Opening files
- The status of files
- File system size checks
- Creation of the scratch file

---

## Note

All initialization errors are fatal when the file system is checked with `fsck -p` or the `preen` utility.

*N* option?

*N* is not a legal option to `fsck`. Legal options are `-b`, `-c`, `-d`, `-f`, `-m`, `-n`, `-p`, and `-y`. The `fsck` utility is terminated when this error occurs. Refer to the `fsck(8)` man page for more information.

cannot alloc *NNN* bytes for blockmap

cannot alloc *NNN* bytes for freemap

cannot alloc *NNN* bytes for statemap

cannot alloc *NNN* bytes for lncntp

A `fsck` request for memory for its virtual memory tables failed. The `fsck` utility is terminated when this error occurs.

Can't open checklist file: *F*

The file system checklist file *F* (usually `/etc/fstab`) cannot be opened for reading. The `fsck` utility is terminated when this error occurs. Check access modes of *F*.

Can't stat root

fsck request for statistics about the root directory (/) failed. The fsck utility is terminated when this error occurs.

Can't stat F

Can't make sense out of name F

fsck request for statistics about the file system F failed. When running manually, it ignores this file system and continues checking the next file system given. Check access modes of F.

Can't open F

fsck request to open the file system F failed. When running manually, it ignores this file system and continues checking the next file system given. Check access modes of F.

F: (NO WRITE)

Either the -n flag was specified or an fsck attempt to open the file system F for writing failed. When running manually, all diagnostics are printed out, but no modifications are made.

file is not a block or character device; OK

You gave fsck a regular file name by mistake. Check the type of file specified.

Possible responses to the OK prompt are:

YES Ignore this error condition.

NO Ignore this file system and continue checking the next file system given.

MAGIC NUMBER WRONG

NCG OUT OF RANGE

CPG OUT OF RANGE

NCYL DOES NOT JIVE WITH NCG\*CPG

SIZE PREPOSTEROUSLY LARGE

TRASHED VALUES IN SUPER BLOCK

followed by the message:

F: BAD SUPER BLOCK: B

USE -b OPTION TO FSCK TO SPECIFY LOCATION OF AN ALTERNATE SUPER-BLOCK TO SUPPLY NEEDED INFORMATION; SEE fsck(8).

The superblock has been corrupted. Select an alternate superblock from among those listed by `newfs` when the file system was created. For file systems with a block size less than 32 kbytes, specifying `-b 32` is a good first choice.

INTERNAL INCONSISTENCY: *M*

The `fsck` utility had an internal panic, whose message is specified as *M*.

CAN NOT SEEK: BLK *B* (CONTINUE)

`fsck` request for moving to specified block number *B* in the file system failed.

Possible responses to the CONTINUE prompt are:

YES        Attempt to continue the file system check. Often, however, the problem will persist. This error condition will not allow a complete check of the file system. Make a second run of `fsck` to recheck this file system. If the block was part of the virtual memory buffer cache, `fsck` terminates with the message "Fatal I/O error".

NO         Terminate the program.

CAN NOT READ: BLK *B* (CONTINUE)

`fsck` request for reading specified block number *B* in the file system failed.

Possible responses to the CONTINUE prompt are:

YES        Attempt to continue the file system check. Often, however, the problem will persist. This error condition will not allow a complete check of the file system. Make a second run of `fsck` to recheck this file system. If the block was part of the virtual memory buffer cache, `fsck` terminates with the message "Fatal I/O error".

NO         Terminate the program.

CAN NOT WRITE: BLK *B* (CONTINUE)

`fsck` request for writing specified block number *B* in the file system failed. The disk is write-protected.

Possible responses to the `CONTINUE` prompt are:

- YES      Attempt to continue the file system check. Often, however, the problem will persist. This error condition will not allow a complete check of the file system. Make a second run of `fsck` to recheck this file system. If the block was part of the virtual memory buffer cache, `fsck` terminates with the message "Fatal I/O error".
- NO      Terminate the program.

---

## Phase 1—Check blocks and sizes

This phase checks the inode list. Error conditions result from:

- Checking inode types
- Setting up the zero-link-count table
- Examining inode block numbers for bad or duplicate blocks
- Checking inode size
- Checking inode format

All errors in this phase except `INCORRECT BLOCK COUNT` are fatal if the file system is being checked with the `preen` command.

```
CG C: BAD MAGIC NUMBER
```

The magic number of cylinder group `C` is wrong. This usually indicates that the cylinder group maps have been destroyed. When running manually, the cylinder group is marked as needing to be reconstructed.

```
UNKNOWN FILE TYPE I=I (CLEAR)
```

The mode word of the inode `I` indicates that the inode is not a special block inode, special character inode, socket inode, regular inode, symbolic link, or directory inode.

Possible responses to the `CLEAR` prompt are:

**YES** Deallocate inode `I` by zeroing its contents. This always invokes the `UNALLOCATED` error condition in Phase 2 for each directory entry pointing to this inode.

**NO** Ignore this error condition.

```
LINK COUNT TABLE OVERFLOW (CONTINUE)
```

An `fsck` internal table containing allocated inodes with a link count of zero has no more room. Recompile `fsck` with a larger value of `MAXLNCNT`.

Possible responses to the `CONTINUE` prompt are:

**YES** Continue with the program. This error condition will not allow a complete check of the file system. Make a second run of `fsck` to recheck this file system. If another allocated inode with a zero link count is found, this error condition is repeated.

**NO** Terminate the program.

`B BAD I=I`

Inode *I* contains block number *B* with a number lower than the number of the first data block in the file system, or greater than the number of the last block in the file system. This error condition may invoke the `EXCESSIVE BAD BLKS` error in Phase 1 if inode *I* has too many block numbers outside the file system range. This error condition always invokes the `BAD/DUP` error in Phase 2 and Phase 4.

`EXCESSIVE BAD BLKS I=I (CONTINUE)`

There is more than a tolerable number (usually 10) of blocks with a number lower than the number of the first data block in the file system, or greater than the number of last block in the file system associated with inode *I*.

Possible responses to the `CONTINUE` prompt are:

**YES** Ignore the rest of the blocks in this inode and continue checking with the next inode in the file system. This error condition will not allow a complete check of the file system. Make a second run of `fsck` to recheck this file system.

**NO** Terminate the program.

`HOLD BAD BLOCK?`

The system has encountered an inode with a mode field of 017, which is an unknown file type.

**YES** Set this inode to indicate a regular file with protection 0600. Set the file size to the size of one fragment.

**NO** Leave the inode as is.

`B DUP I=I`

Inode *I* contains block number *B*, and block number *B* is already claimed by another inode. This error condition may invoke the `EXCESSIVE DUP BLKS` error condition in Phase 1 if inode *I* has too many block numbers claimed by other inodes. This error condition always invokes Phase 1B and the `BAD/DUP` error in Phase 2 and Phase 4.

`EXCESSIVE DUP BLKS I=I (CONTINUE)`

Other inodes claim more than a tolerable number (usually 10) of blocks claimed by other inodes.

Possible responses to the CONTINUE prompt are:

YES Ignore the rest of the blocks in this inode and continue checking with the next inode in the file system. This error condition will not allow a complete check of the file system. Make a second run of `fsck` to recheck this file system.

NO Terminate the program.

DUP TABLE OVERFLOW (CONTINUE)

An `fsck` internal table containing duplicate block numbers has no more room.

Possible responses to the CONTINUE prompt are:

YES Continue with the program. This error condition will not allow a complete check of the file system. Make a second run of `fsck` to recheck this file system. If `fsck` finds another duplicate block, this error condition will repeat.

NO Terminate the program.

PARTIALLY ALLOCATED INODE I=I (CLEAR)

Inode *I* is neither allocated nor unallocated.

Possible responses to the CLEAR prompt are:

YES Deallocate inode *I* by zeroing its contents.

NO Ignore this error condition.

INCORRECT BLOCK COUNT I=I (X should be Y)  
(CORRECT)

The block count for inode *I* is *X* blocks, but should be *Y* blocks. The count is corrected when executing the `preen` utility.

Possible responses to the CORRECT prompt are:

YES Replace the block count of inode *I* with *Y*.

NO Ignore this error condition.

---

## Phase 1B—Rescan for more DUPS

When a duplicate block is found in the file system, `fsck` rescans the file system to find the inode that previously claimed that block. The following error condition occurs when the duplicate block is found.

`B DUP I=I`

Inode *I* contains block number *B* that is already claimed by another inode. This error condition always invokes the `BAD/DUP` error condition in Phase 2. You can determine which inodes have overlapping blocks by examining this error condition and the `DUP` error condition in Phase 1.

---

## Phase 2—Check path names

In this phase, `fsck` removes directory entries pointing to inodes with error conditions in Phase 1 and Phase 1B. Error conditions can occur from:

- Root inode mode and status
- Directory inode pointers out of range
- Directory entries pointing to bad inodes

All errors in this phase are fatal if the file system is being checked with the `preen` command.

```
ROOT INODE UNALLOCATED. TERMINATING.
```

The root inode (usually inode number 2) has no allocate mode bits. The program will terminate.

```
NAME TOO LONG F
```

`fsck` found an excessively long path name. This usually indicates loops in the file system name space. This can occur if the superuser made circular links to directories. Remove the circular links.

```
ROOT INODE NOT DIRECTORY (FIX)
```

The root inode (usually inode number 2) is not a directory inode type.

Possible responses to the `FIX` prompt are:

- YES        Make the root inode type a directory. If the root inode data blocks are not directory blocks, a *very* large number of error conditions will be produced.
- NO        Terminate the program.

```
DUPS/BAD IN ROOT INODE (CONTINUE)
```

Phase 1 or Phase 1B found duplicate blocks or bad blocks in the root inode (usually inode number 2) for the file system.

Possible responses to the `CONTINUE` prompt are:

- YES        Ignore the `DUPS/BAD` error condition in the root inode and attempt to continue the file system check. If the root inode is not correct, this may result in a large number of other error conditions.
- NO        Terminate the program.

*I* OUT OF RANGE *I*=*I* NAME=*F* (REMOVE)

Inode number *I* of directory *F* is greater than the end of the inode list.

Possible responses to the REMOVE prompt are:

YES Remove directory entry *F*.

NO Ignore this error condition.

```
UNALLOCATED I=I OWNER=O MODE=M
SIZE=S MTIME=T DIR F REMOVE [yn]
```

Directory *F* has a directory inode *I* without allocate mode bits. The owner *O*, mode *M*, size *S*, modify time *T*, and directory name *F* are printed.

Possible responses to the REMOVE prompt are:

YES Remove directory entry *F*.

NO Ignore this error condition.

```
UNALLOCATED I=I OWNER=O MODE=M
SIZE=S MTIME=T FILE F REMOVE [yn]
```

File *F* has an inode *I* without allocate mode bits. The owner *O*, mode *M*, size *S*, modify time *T*, and file name *F* are printed.

Possible responses to the REMOVE prompt are:

YES Remove directory entry *F*.

NO Ignore this error condition.

```
DUP/BAD I=I OWNER=O MODE=M SIZE=S MTIME=T
DIR=F (REMOVE)
```

Phase 1 or Phase 1B found duplicate blocks or bad blocks associated with directory entry *F* and directory inode *I*. The owner *O*, mode *M*, size *S*, modify time *T*, and directory name *F* are printed.

Possible responses to the REMOVE prompt are:

YES Remove directory entry *F*.

NO Ignore this error condition.

```
DUP/BAD I=I OWNER=O MODE=M SIZE=S MTIME=T
FILE=F (REMOVE)
```

Phase 1 or Phase 1B found duplicate blocks or bad blocks associated with directory entry *F* and inode *I*. The owner *O*, mode *M*, size *S*, modify time *T*, and file name *F* are printed.

Possible responses to the REMOVE prompt are:

YES Remove directory entry *F*.

NO Ignore this error condition.

```
ZERO LENGTH DIRECTORY I=I OWNER=O MODE=M
SIZE=S MTIME=T DIR=F (REMOVE)
```

Size *S* of directory *F* is zero. The owner *O*, mode *M*, size *S*, modify time *T*, and directory name *F* are printed.

Possible responses to the REMOVE prompt are:

YES Remove directory entry *F*. This always invokes the BAD/DUP error condition in Phase 4.

NO Ignore this error condition.

```
DIRECTORY TOO SHORT I=I OWNER=O MODE=M
SIZE=S MTIME=T DIR=F (FIX)
```

Size *S* of directory *F* is less than the minimum size directory. The owner *O*, mode *M*, size *S*, modify time *T*, and directory name *F* are printed.

Possible responses to the FIX prompt are:

YES Increase directory size to the minimum directory size.

NO Ignore this directory.

```
DIRECTORY CORRUPTED I=I OWNER=O MODE=M
SIZE=S MTIME=T DIR=F (SALVAGE)
```

Directory *F* has an inconsistent internal state.

Possible responses to the SALVAGE prompt are:

YES Throw away all entries up to the next 512-byte boundary. This action can throw away up to 42 entries, and should be taken only after other recovery efforts have failed.

NO Skip up to the next 512-byte boundary and resume checking, but do not modify the directory.

```
BAD INODE NUMBER FOR '.' I=I OWNER=O MODE=M
SIZE=S MTIME=T DIR=F (FIX)
```

The inode number for '.' of directory *I* is unallocated.

Possible responses to the FIX prompt are:

YES Change the inode number for '.' to be equal to *I*.

NO Leave the inode number for '.' unchanged.

```
MISSING `.' I=I OWNER=O MODE=M SIZE=S
MTIME=T DIR=F (FIX)
```

The first entry of directory *I* is unallocated.

Possible responses to the FIX prompt are:

YES        Make an entry for *'.'* with inode number equal to *I*.

NO        Leave the directory unchanged.

```
MISSING `.' I=I OWNER=O MODE=M SIZE=S
MTIME=T DIR=F
CANNOT FIX, FIRST ENTRY IN DIRECTORY
CONTAINS F
```

The first entry of directory *I* is *F*. The `fsck` utility cannot resolve this problem. Mount the file system and move the entry *F* elsewhere. Then, unmount the file system and run `fsck` again.

```
MISSING `.' I=I OWNER=O MODE=M SIZE=S
MTIME=T DIR=F
CANNOT FIX, INSUFFICIENT SPACE TO ADD `.'
```

The first entry of directory *I* is not *'.'*

```
EXTRA `.' ENTRY I=I OWNER=O MODE=M SIZE=S
MTIME=T DIR=F (FIX)
```

Directory *I* has more than one entry for *'.'*

Possible responses to the FIX prompt are:

YES        Remove the extra entry for *'.'*

NO        Leave the directory unchanged.

```
BAD INODE NUMBER FOR `..' I=I OWNER=O MODE=M
SIZE=S MTIME=T DIR=F (FIX)
```

The inode number for *'..'* of directory *I* does not equal the parent of *I*.

Possible responses to the FIX prompt are:

YES        Change the inode number for *'..'* to be equal to the parent of *I*.

NO        Leave the inode number for *'..'* unchanged.

```
MISSING `..' I=I OWNER=O MODE=M SIZE=S
MTIME=T DIR=F (FIX)
```

The second entry of directory *I* is unallocated.

Possible responses to the FIX prompt are:

YES        Make an entry for '..' with inode number equal to the parent of *I*.

NO        Leave the directory unchanged.

```
MISSING '..' I=I OWNER=O MODE=M SIZE=S
MTIME=T DIR=F
CANNOT FIX, SECOND ENTRY IN DIRECTORY
CONTAINS F
```

The second entry of directory *I* is *F*. *fsck* cannot resolve this problem. Mount the file system and move entry *F* elsewhere. Then, unmount the file system and run *fsck* again.

```
MISSING '..' I=I OWNER=O MODE=M SIZE=S
MTIME=T DIR=F
CANNOT FIX, INSUFFICIENT SPACE TO ADD '..'
```

The second entry of directory *I* is not '..'.

```
EXTRA '..' ENTRY I=I OWNER=O MODE=M SIZE=S
MTIME=T DIR=F (FIX)
```

Directory *I* has more than one entry for '..'.

Possible responses to the FIX prompt are:

YES        Remove the extra entry for '..'.

NO        Leave the directory unchanged.

---

### Phase 3—Check connectivity

This phase checks the directory connectivity seen in Phase 2. This section lists error conditions resulting from unreferenced directories and missing or full lost+found directories.

```
UNREF DIR I=I OWNER=O MODE=M SIZE=S MTIME=T (RECONNECT)
```

The directory inode *I* was not connected to a directory entry when `fsck` traversed the file system. The owner *O*, mode *M*, size *S*, and modify time *T* of directory inode *I* are printed. When executing the `preen` utility, the directory is reconnected if its size is nonzero; otherwise it is cleared.

Possible responses to the `RECONNECT` prompt are:

- YES        Reconnect directory inode *I* to the file system in the directory for lost files (usually lost+found). This may invoke the lost+found error condition in Phase 3 if there are problems connecting directory inode *I* to lost+found. This may also invoke the `CONNECTED` error condition in Phase 3 if the link was successful.
- NO        Ignore this error condition. This always invokes the `UNREF` error condition in Phase 4.

```
SORRY. NO lost+found DIRECTORY
```

There is no lost+found directory in the root directory of the file system; `fsck` attempted to create this directory but was unable to do so. This always invokes the `UNREF` error condition in Phase 4. Check access modes of lost+found. Refer to the `fsck(8)` man page for more information. This error is fatal if the file system is being checked using the `preen` command.

```
SORRY. NO SPACE IN lost+found DIRECTORY
```

There is no space to add another entry to the lost+found directory in the root directory of the file system; `fsck` attempted to expand this directory but was unable to do so. This always invokes the `UNREF` error condition in Phase 4. Clean out unnecessary entries in lost+found or make lost+found larger. Refer to the `fsck(8)` man page for more information. This error is fatal if the file system is being checked using the `preen` command.

```
DIR I=I1 CONNECTED. PARENT WAS I=I2
```

This is an advisory message: directory inode *I1* was successfully connected to the lost+found directory. The parent inode *I2* of the directory inode *I1* is replaced by the inode number of the lost+found directory.

---

## Phase 4—Check reference counts

This phase checks the link count information seen in Phase 2 and Phase 3. This section lists error conditions resulting from:

- Unreferenced files
- Missing or full lost+found directory
- Incorrect link counts for files, directories, symbolic links, or special files
- Unreferenced files, symbolic links, and directories
- Bad and duplicate blocks in files, symbolic links, and directories
- Incorrect total free-inode counts

All errors in this phase can be corrected if the file system is being checked using the `preen` command, except for errors resulting from running out of space in the lost+found directory.

```
UNREF FILE I=I OWNER=O MODE=M SIZE=S MTIME=T
(RECONNECT)
```

Inode *I* was not connected to a directory entry when the file system was traversed. The owner *O*, mode *M*, size *S*, and modify time *T* of inode *I* are printed. When checking the file system using the `preen` command, the file is cleared if either its size or its link count is zero; otherwise it is reconnected.

Possible responses to the `RECONNECT` prompt are:

- YES        Reconnect inode *I* to the file system in the directory for lost files (usually lost+found). This may invoke the lost+found error condition in Phase 4 if there are problems connecting inode *I* to lost+found.
- NO         Ignore this error condition. This always invokes the `CLEAR` error condition in Phase 4.

(CLEAR)

The inode mentioned in the previous error condition cannot be reconnected. This cannot occur if the file system is being checked using the `preen` command, because lack of space for reconnecting files is a fatal error.

Possible responses to the `CLEAR` prompt are:

- YES        Deallocate the inode mentioned in the immediately previous error condition by zeroing its contents.
- NO         Ignore this error condition.

SORRY. NO lost+found DIRECTORY

There is no lost+found directory in the root directory of the file system; `fsck` attempted to create this directory but was unable to do so. This always invokes the CLEAR error condition in Phase 4. Check access modes of lost+found. This error is fatal if the file system is being checked using the `preen` command.

SORRY. NO SPACE IN lost+found DIRECTORY

There is no space to add another entry to the lost+found directory in the root directory of the file system; `fsck` attempted to expand this directory but was unable to do so. This always invokes the CLEAR error condition in Phase 4. Check size and contents of lost+found. This error is fatal if the file system is being checked using the `preen` command.

```
LINK COUNT FILE I=I OWNER=O MODE=M SIZE=S
MTIME=T COUNT=X SHOULD BE Y (ADJUST)
```

The link count for inode *I*, which is a file, is *X* but should be *Y*. The owner *O*, mode *M*, size *S*, and modify time *T* are printed. When checking the file system using the `preen` command, the link count is adjusted.

Possible responses to the ADJUST prompt are:

YES        Replace the link count of file inode *I* with *Y*.

NO        Ignore this error condition.

```
LINK COUNT DIR I=I OWNER=O MODE=M SIZE=S
MTIME=T COUNT=X SHOULD BE Y (ADJUST)
```

The link count for inode *I*, which is a directory, is *X* but should be *Y*. The owner *O*, mode *M*, size *S*, and modify time *T* of directory inode *I* are printed. When checking the file system using the `preen` command, the link count is adjusted.

Possible responses to the ADJUST prompt are:

YES        Replace the link count of directory inode *I* with *Y*.

NO        Ignore this error condition.

```
LINK COUNT F I=I OWNER=O MODE=M SIZE=S
MTIME=T COUNT=X SHOULD BE Y (ADJUST)
```

The link count for *F* inode *I* is *X* but should be *Y*. The name *F*, owner *O*, mode *M*, size *S*, and modify time *T* are printed. When checking the file system using the `preen` command, the link count is adjusted.

Possible responses to the ADJUST prompt are:

- YES        Replace the link count of inode *I* with *Y*.
- NO        Ignore this error condition.

```
UNREF FILE I=I OWNER=O MODE=M SIZE=S MTIME=T
(CLEAR)
```

Inode *I*, a file, was not connected to a directory entry when the file system was traversed. The owner *O*, mode *M*, size *S*, and modify time *T* of inode *I* are printed. When checking the file system using the `preen` command, this file was not connected because its size or link count was zero; hence it is cleared.

Possible responses to the CLEAR prompt are:

- YES        Deallocate inode *I* by zeroing its contents.
- NO        Ignore this error condition.

```
UNREF DIR I=I OWNER=O MODE=M SIZE=S MTIME=T
(CLEAR)
```

Inode *I*, a directory, was not connected to a directory entry when the file system was traversed. The owner *O*, mode *M*, size *S*, and modify time *T* of inode *I* are printed. When checking the file system using the `preen` command, this directory was not connected because its size or link count was zero, hence it is cleared.

Possible responses to the CLEAR prompt are:

- YES        Deallocate inode *I* by zeroing its contents.
- NO        Ignore this error condition.

```
BAD/DUP FILE I=I OWNER=O MODE=M SIZE=S
MTIME=T (CLEAR)
```

Phase 1 or Phase 1B found duplicate blocks or bad blocks associated with file inode *I*. The owner *O*, mode *M*, size *S*, and modify time *T* of inode *I* are printed. This error cannot occur when the file system is being checked using the `preen` command, because it would have caused a fatal error earlier.

Possible responses to the CLEAR prompt are:

- YES        Deallocate inode *I* by zeroing its contents.
- NO        Ignore this error condition.

```
BAD/DUP DIR I=I OWNER=O MODE=M SIZE=S
MTIME=T (CLEAR)
```

Phase 1 or Phase 1B found duplicate blocks or bad blocks associated with directory inode *I*. The owner *O*, mode *M*, size *S*, and modify time *T* of inode *I* are printed. This error cannot occur when the file system is being checked using the `preen` command, because it would have caused a fatal error earlier.

Possible responses to the `CLEAR` prompt are:

YES Deallocate inode *I* by zeroing its contents.

NO Ignore this error condition.

```
FREE INODE COUNT WRONG IN SUPERBLK (FIX)
```

The actual count of free inodes does not match the count in the file system superblock. When checking the file system using the `preen` command, the count is fixed.

Possible responses to the `FIX` prompt are:

YES Replace the count in the superblock by the actual count.

NO Ignore this error condition.

---

## Phase 5—Check cylinder groups

This phase checks the free-block maps. This section lists error conditions resulting from allocated blocks in the free-block maps, free blocks missing from free-block maps, and the total free-block count that is incorrect.

CG C: BAD MAGIC NUMBER

The magic number of cylinder group C is wrong. This usually indicates that the cylinder group maps have been destroyed. When run manually, the cylinder group is marked as needing reconstruction. This error is fatal if the file system is being checked using the `preen` command.

EXCESSIVE BAD BLKS IN BIT MAPS (CONTINUE)

An inode contains more than a tolerable number (usually 10) of blocks claimed by other inodes or, the number is out of the legal range for the file system. This error is fatal if the file system is being checked using the `preen` command.

Possible responses to the CONTINUE prompt are:

YES        Ignore the rest of the free-block maps and continue execution of `fsck`.

NO         Terminate the program.

SUMMARY INFORMATION T BAD

where T can be one or more of the following:

(INODE FREE)

(BLOCK OFFSETS)

(FRAG SUMMARIES)

(SUPER BLOCK SUMMARIES)

The indicated summary information is incorrect. When checking the file system using the `preen` command, the summary information is recomputed.

X BLK(S) MISSING

X blocks unused by the file system were not found in the free-block maps. When checking the file system using the `preen` command, block maps are rebuilt.

#### BAD CYLINDER GROUPS (SALVAGE)

There are bad blocks in the free-block maps, duplicate blocks in the free-block maps, or blocks missing from the file system. When checking the file system using the `preen` command, the cylinder groups are reconstructed.

Possible responses to the `SALVAGE` prompt are:

- YES        Replace the actual free-block maps with new free-block maps.
- NO        Ignore this error condition.

#### FREE BLK COUNT WRONG IN SUPERBLOCK (FIX)

The actual count of free blocks does not match the count in the file system superblock. When checking the file system using the `preen` command, the counts are fixed.

Possible responses to the `FIX` prompt are:

- YES        Replace the count in the superblock by the actual count.
- NO        Ignore this error condition.

---

### **Phase 6—Salvage cylinder groups**

This phase reconstructs the free-block maps. No error messages are produced.

---

## Clean-up

After a file system has been checked, clean-up procedures are performed. This section lists advisory messages about the file system and modify status of the file system.

```
V files, W used, X free (Y frags, Z blocks)
```

This advisory message indicates that the file system contained *V* files using *W* fragments, leaving *X* fragments free in the file system. Numbers in parentheses breaks the free count down into *Y* free fragments and *Z* free full-sized blocks.

```
***** REBOOT ConvexOS *****
```

This advisory message indicates that the root file system has been modified by *fsck*. If ConvexOS is not rebooted immediately, the work done by *fsck* may be destroyed by the copies of tables ConvexOS keeps. When checking the file system using the *preen* command, *fsck* will exit with a code of 4. The */etc/rc* script interprets an exit code of 4 by issuing a *reboot* system call.

```
***** FILE SYSTEM WAS MODIFIED *****
```

This advisory message indicates that *fsck* modified the current file system. If this file system is mounted or is the current root file system, halt *fsck* and reboot ConvexOS. If ConvexOS is not rebooted immediately, the work done by *fsck* may be destroyed by the copies of tables ConvexOS keeps.



This chapter provides information on using the `crashdump` utility after a system crash. It includes information on:

- What a crash dump is
- How to perform a crash dump using:
  - The default tape drive
  - A tape drive other than the default
  - The SPU tape drive
- What to do with the crash dump once you have finished making the tape
- How to restart a crash dump if you have tape problems

This chapter does not give details on analyzing crash dumps.

---

## Caution

---

**If you are performing a crash dump, you must do so before rebooting the system after a crash. Rebooting the system initializes memory, destroying the contents of registers that are needed in order to analyze the crash.**

---

## Crash dump overview

When a system crashes unexpectedly, you can use its service processor unit (SPU) to create a crash dump. A crash dump is a collection of files that describes the state of a system immediately after a crash.

Systems may crash occasionally due to anomalies that may never reoccur. In this circumstance, a crash dump is not necessary and rebooting the system is all that is required.

Chronic system problems may exist on rare occasions that require further investigation. When a system crashes repeatedly with the message "ConvexOS: FATAL ERROR," or hangs (no panic message, but nothing runs), a crash dump should be recorded to tape. After completing a crash dump under these circumstances, contact the CONVEX Technical Assistance Center (TAC) for a Problem Report (PR) number, which identifies your system problem with the crash dump.

Once a crash dump and its PR number are received by the TAC, specialists can analyze the crash and offer information about how to prevent future occurrences.

---

## Performing crash dumps on a variety of tape drives

This section describes how to prepare for and execute a crash dump. It also describes what to do with the crash dump once it has been recorded onto tape.

There are three ways to record a crash dump. You can use:

- A local 9-track tape drive, `mt:0`, which is the default for `crashdump`
- A local tape drive other than the default
- An `mt`-format cartridge or DAT SPU tape drive

You can only perform a crash dump on a local tape drive (9-track, rack-mount 3480 cartridge, rack-mount DAT) or a SPU tape drive (`mt` format or DAT only). Crash dumps to 3480 cartridge or DAT drives that are not rack-mounted, remote tape drives, or to `ct`-format SPU drives are not supported.

---

### Caution

---

**Do not execute a standalone hardware dump before running `crashdump`. Hardware dumps alter the CPU register state, making it difficult to analyze a potential software problem.**

---

## Performing a crash dump using the default, 9-track drive

- Step 1** Mount a tape on the mt:0 9-track drive:
- Use a 2400-foot reel tape.
  - Place the tape drive online by pressing the **On line** key on the tape drive.
  - Make sure the density on the drive is set for 6250.
- Step 2** Make sure the keyswitch on the Front Panel is in the LOCAL position.
- Step 3** Make sure you have a SPU prompt, which looks like this:
- ```
(spu) >
```
- If you do not have a SPU prompt, enter the SPU by pressing **CTRL-p**.
- Step 4** Make sure you are at the /mnt/os directory of the SPU. Enter at the SPU prompt:
- ```
(spu) > pwd
```
- Step 5** If you are not in the /mnt/os directory, change to the /mnt/os directory on the SPU. Enter at the SPU prompt:
- ```
(spu) > cd /mnt/os
```
- Step 6** End execution of all programs other than the standard shell program run by the SPU. Enter at the SPU prompt:
- ```
(spu) > osclean
```
- Step 7** Append the register contents to the errlog file. Enter at the SPU prompt:
- ```
(spu) > cpureg >> /mnt/errlog
```
- Step 8** If you are using the default 9-track tape drive, begin the crash dump by entering at the SPU prompt:
- ```
(spu) > crashdump -H
```

Figure 47 displays the message generated when `crashdump` is started.

**Figure 47** Example crashdump output on start

```
(spu)> crashdump -H
Crashdump started Fri Apr 24 13:53:57 CDT 1992
Using hwdump.out
.
.
.
Using /mnt/os/vmunix
```

**Step 9** Enter a comment to be included with the crash dump tapes when you are prompted to do so. Provide the following:

- Machine name
- Condition of the machine at crash time
- Problem report number
- Name and number of a person who can be contacted about the crash
- The last time the machine crashed
- Anything else that might be helpful to the TAC.

Figure 48 is an example of a crash dump comment.

**Figure 48** Example crashdump comment

```
Please enter any comments you have on this crashdump.
Enter ctrl-D on a line by itself to end:
>jupiter (C2400)
>jupiter crashes when the program jinx is running
>PR-1313
>Pat Smith (214) 555-5274
>Last crash was 4/27/92
>^D
The dump will now continue...
```

After crashdump begins, status messages are displayed on the SPU console to tell you how the crash dump is progressing.

**Step 10** If you are dumping large amounts of memory and need more than one tape, you are prompted when it is necessary to change tapes. Remove the tape that is currently on the drive and replace it with a new tape. Press the RETURN key.

Figure 49 shows the prompt to change tapes.

**Figure 49** Example mount tape prompt

```
Load next tape (#2 of 2) to continue.
Type <CR> when ready:
```

When changing a tape, ensure that each tape is accurately labeled.

**Step 11** When `crashdump` completes writing to tape, it sends a message to the console as in Figure 50.

**Figure 50** Example of successful crash dump completion

```
Writing rest of main memory to tape...
mmdump successful
spu>█
```

After receiving this message you can remove the tape from the drive. Label the tape with the following information:

- Site name and address
- Problem report number
- Name and number of a person who can be contacted about the crash
- If there is more than one volume, please number the tapes.

---

## Performing a crash dump using a tape drive other than the default

- Step 1** Mount a blank tape in the appropriate tape drive (9-track, rack-mount (SCSI) 3480 cartridge, DAT, or SPU).  
If you are using a 9-track drive:
- Use a 2400-foot reel tape.
  - Place the tape drive online by pressing the **On line** key on the tape drive.
  - Make sure the density on the drive is set for 6250.
- Step 2** Make sure the keyswitch is in the LOCAL position.
- Step 3** Make sure you have a SPU prompt, which looks like this:  
(spu) >
- If you do not have a SPU prompt, enter the SPU by pressing **CTRL-p**.
- Step 4** Make sure you are at the /mnt/os directory of the SPU. Enter at the SPU prompt:  
(spu) > **pwd**
- Step 5** If you are not in the /mnt/os directory, change to the /mnt/os directory on the SPU. Enter at the SPU prompt:  
(spu) > **cd /mnt/os**
- Step 6** End execution of all programs other than the standard shell program run by the SPU. Enter at the SPU prompt:  
(spu) > **osclean**
- Step 7** Append the register contents to the errlog file. Enter at the SPU prompt:  
(spu) > **cpureg >> /mnt/errlog**
- Step 8** Enter at the SPU prompt:  
(spu) > **crashdump -S -H**

Figure 51 displays the message generated when `crashdump` is started.

**Figure 51** Example of initial crashdump output

```
(spu)> crashdump -S -H
Crashdump started Fri Apr 24 13:53:57 CDT 1992
Using hwdump.out
.
.
.
Using /mnt/os/vmunix
```

**Step 9** Enter a comment to be included with the crash dump tapes when you are prompted to do so. Provide the following:

- Machine name
- Condition of the machine at crash time
- Problem report number
- Name and number of a person who can be contacted about the crash
- The last time the machine crashed
- Anything else that might be helpful to the TAC

Figure 52 is an example of a crash dump comment.

**Figure 52** Example of a crashdump comment

```
Please enter any comments you have on this crashdump.
Enter ctrl-D on a line by itself to end:
>jupiter (C2400)
>jupiter crashes when the program jinx is running
>PR-1313
>Pat Smith (214) 555-5274
>Last crash was 4/27/92
>^D
The dump will now continue...
```

- Step 10** Select the alternate drive you are using for the crash dump. Enter an integer that corresponds to one of the drives that is available. In Figure 53 a rack-mounted, 3480 cartridge drive is selected.

**Figure 53** Example of selecting an alternate drive for crashdump

```

Drive# | Type | Ctlr | Chassis | CCU | Unit# | Sub-Unit#
=====
 0 | SPUTAPE | rmt1 | | 0 | 0 | 0 | 0
 1 | MTD-001 | MTC-001 | | 0 | 0 | 0 | 0
 2 | MTD-207 | MTC-202 | | 0 | 0 | 0 | 0
 3 | MTD-207 | MTC-202 | | 0 | 0 | 1 | 0

```

```

Which tape drive do you wish to use? ('a' to abort):2
Mon Apr 27 13:55:37 CDT 1992

```

Because `crashdump` runs from the SPU, tape drives are listed according to their entries in the SPU's `/ioconfig` file. Table 4 shows the tape system drive types and their corresponding types in the SPU's `/ioconfig` file.

**Table 4** Tape system and SPU `/ioconfig` drive types

| Tape system drive type | SPU <code>/ioconfig</code> drive type |
|------------------------|---------------------------------------|
| mt                     | MTD-001                               |
|                        | MTD-002                               |
|                        | MTD-003                               |
|                        | MTD-004                               |
|                        | MTD-005                               |
|                        | MTD-203                               |
|                        | MTD-204                               |
| ct                     | MTD-207                               |
| dat                    | MTD-208                               |

After `crashdump` begins, status messages, starting with the date and time, are displayed on the SPU console to tell you how the crash dump is progressing.

- Step 11** If you are dumping large amounts of memory and need more than one tape, you are prompted when it is necessary to change tapes. Remove the tape that is currently on the drive and replace it with a new tape. Press the **RETURN** key.

Figure 54 shows the prompt to change tapes.

**Figure 54** Example mount tape prompt

```
Load next tape (#2 of 2) to continue.
Type <CR> when ready:
```

When changing a tape, ensure that each tape is accurately labeled.

- Step 12** When `crashdump` completes writing to tape, it sends a message to the console as shown in Figure 55.

**Figure 55** Example of successful `crashdump` completion

```
Writing rest of main memory to tape...
mmdump successful
spu> █
```

After receiving this message you can remove the tape from the drive. Label the tape with the following information:

- Site name and address
- Problem report number
- Name and number of a person who can be contacted about the crash
- If there is more than one volume, please number the tapes.

---

## Performing a crash dump using the SPU tape drive

- Step 1** Mount a blank tape in the SPU tape drive (mt-format or DAT only).
- Step 2** Make sure the keyswitch is in the LOCAL position.
- Step 3** Make sure you have a SPU prompt, which looks like this:  
(spu) >
- If you do not have a SPU prompt, enter the SPU by pressing CTRL-p.
- Step 4** Make sure you are at the /mnt/os directory of the SPU. Enter at the SPU prompt:  
(spu) > **pwd**
- Step 5** If you are not in the /mnt/os directory, change to the /mnt/os directory on the SPU. Enter at the SPU prompt:  
(spu) > **cd /mnt/os**
- Step 6** Rewind the SPU tape. Enter at the SPU prompt:  
(spu) > **mt rew**
- Step 7** End execution of all programs other than the standard shell program run by the SPU. Enter at the SPU prompt:  
(spu) > **osclean**
- Step 8** Append the register contents to the errlog file. Enter at the SPU prompt:  
(spu) > **cpureg >> /mnt/errlog**
- Step 9** Enter at the SPU prompt:  
(spu) > **crashdump -s -H**

Figure 56 displays the message generated when crashdump is started.

**Figure 56** Example crashdump output on start

```
(spu)> crashdump -s -H
Crashdump started Fri Apr 24 13:53:57 CDT 1992
Using hwdump.out
.
.
.
Using /mnt/os/vmunix
```

- Step 10** Enter a comment to be included with the crash dump tapes when you are prompted to do so. Provide the following:
- Machine name
  - Condition of the machine at crash time
  - Problem report number
  - Name and number of a person who can be contacted about the crash
  - The last time the machine crashed
  - Anything else that might be helpful to the TAC.

Figure 57 is an example of a crash dump comment.

**Figure 57** Example `crashdump` comment

```
Please enter any comments you have on this crashdump.
Type CTRL-d on a line by itself to end:
>jupiter (C2400)
>jupiter crashes when the program jinx is running
>PR-1313
>Pat Smith (214) 555-5274
>Last crash was 4/27/92
>^D
The dump will now continue...
```

After `crashdump` begins, status messages are displayed on the SPU console to tell you how the crash dump is progressing.

- Step 11** If you are dumping large amounts of memory and need more than one tape, you are prompted when it is necessary to change tapes. Remove the tape that is currently on the drive and replace it with a new tape. Press the **RETURN** key.

Figure 58 on the following page shows the prompt to change tapes.

**Figure 58** Example mount tape prompt

```
Load next tape (#2 of 2) to continue.
Type <CR> when ready:
```

When changing a tape, ensure that each tape is accurately labeled.

**Step 12** When `crashdump` completes writing to tape, it sends a message to the console as in Figure 59.

**Figure 59** Example of successful `crashdump` completion

```
Writing rest of main memory to tape...
mmdump successful
spu> █
```

After receiving this message, you can remove the tape from the drive. Label the tape with the following information:

- Site name and address
- Problem report number
- Name and number of a person who can be contacted about the crash
- If there is more than one volume, please number the tapes.

---

## What to do with crash dump tapes

When the crash dump is complete, label the tape or tapes. Labels on all crash dump tapes should contain the following information:

- Problem Report (PR) number, which is obtained from the TAC
- CPU number of the system that crashed
- Tape volume numbers, if the crash dump is on more than one tape
- Date the crash dump was performed
- Site name
- ConvexOS version number
- Your name and phone number, or the name and phone number of an individual who is familiar with the crash

If a crash dump tape is 9-track, before packaging it to send to the TAC, use a strap, foam block, or similar device to hold the loose end of the tape in place. This reduces the risk of damage during shipment.

After securely packaging the tape or tapes, send them to the following address:

CONVEX Computer Corporation  
Technical Assistance Center  
Richardson, TX 75083-3851  
USA

---

## Restarting a crash dump

Most crash dump errors occur before `crashdump` begins writing to tape and involve improper use of the tape system. For 9-track drives, for example, if the tape drive is not online, `crashdump` reports the error shown in Figure 60.

Figure 60 Example `crashdump` error

```
Tape not online ... put online and press return
```

Tape system errors that occur before `crashdump` begins writing to tape do not terminate `crashdump`. As the example shows, the `crashdump` utility reports the error and prompts to respond when the error is corrected, and you are ready to continue.

Errors that occur after `crashdump` has started writing to tape cause `crashdump` to terminate. It is not advisable to restart `crashdump` in this case. Contact the TAC to determine what can be done.



After a system crash, it is best to work from the most basic components of the file system outward. Otherwise, corrections made at the higher levels may be undone by programs fixing the lower levels. You must be root to perform these tasks. Follow the order of recovery steps as presented below.

**Step 1** Perform a crash dump.  
Refer to Chapter 9 for details on how to do this.

**Step 2** Boot to single-user mode. Enter:

```
(spu) > boot single
```

If a disk failure is not recorded, back-up data for any redundant stripes using that disk will be destroyed by a `preen`. In the unlikely event that a disk drive failed at the same time the machine crashed, perform the following steps. Otherwise, skip to Step 6.

**Step 3** In single user mode, enter:

```
% qst
```

**Step 4** If the `qst` output reveals that one or more redundant stripes used the failed disk, enter:

```
% getst stxx
```

for each stripe `stxx` that included the failed disk. If the `getst` output shows the disk marked as failed, continue the crash recovery procedure starting at Step 6. Refer to Appendix B for disk failure recovery procedures.

**Step 5** If `getst` does not show the disk failure, use `mvst` to move data from the failed disk onto a replacement disk or a hot spare partition. If you replaced the failed disk, enter:

```
% mvst /dev/stxx /dev/dbad
```

where `stxx` is the stripe containing the bad disk and `/dev/dbad` is the device number of the failed disk (and its replacement). To move the data to a hot spare partition, enter

```
% mvst -H /dev/stxx /dev/dbad
```

where *stxx* is the stripe containing the failed disk and */dev/dbad* is the device number of the failed disk.

*mvst* marks the disk as failed, so once you initiate the *mvst*, it is safe to run *preen* on your file systems.

**Step 6** Run *preen* to check the file systems. There may be user, system, or audit files in the process of being built when the system crashes. Although that data may be lost, *preen* can recover some of those files in the lost+found directory of the file system and can fix basic file system problems. Enter:

```
% preen
```

**Step 7** Boot the system to multiuser mode. Press **CTRL-D**.  
Users can now start using the system.

---

# Line printer system error messages

# A

The ConvexOS line printer system may produce any of the following error messages or warnings. These messages are categorized according to the printer utility that produces them, as listed below:

- `lpc`
- `lpd`
- `lpmv`
- `lpq`
- `lpr`
- `lprm`

If you encounter error messages that are not described, this may indicate a serious internal error. In that case, please contact the CONVEX Technical Assistance Center (TAC).

Throughout this appendix, the term *printer* is the name of a printer from the `/etc/printcap` file.

---

## lpc error messages

The following messages are produced by the `lpc` utility:

```
cannot examine spool directory
```

Error messages that begin with “cannot” are usually caused by incorrect ownership or protection mode of the lock file, spooling directory, or the `lpc` utility. Run the `/etc/verify` command to determine if any files or directories do not have the proper characteristics.

```
couldn't start printer
```

The connection to the line printer daemon, `lpd`, on the local machine failed. This usually means that the master printer daemon started during the boot process has died or is hung. To determine whether the daemon is running, enter:

```
% /etc/lpc status printer
```

You can also determine whether the daemon is running with the following command:

```
% ps ax | grep lpd | grep -v grep
```

If no `/usr/lib/lpd` process is displayed, restart the daemon using the `lpc restart` command

```
% /etc/lpc restart printer
```

or enter

```
% /usr/lib/lpd
```

Another possibility is that the `lpc` program does not have its owner and group set to `daemon`, or the `setuid` and `setgid` are not set. This can be checked with the command:

```
% ls -lg /usr/etc/lpc
```

The following message will be displayed if everything is set correctly:

```
-rwsr-sr-x 1 lpr lpr 143807 Jun 29 16:57
/usr/etc/lpc
```

---

## lpd error messages

The lpd process can log many different messages using `syslogd`. Most of these messages are about files that cannot be opened and usually indicate that the `/etc/printcap` file or the protection modes of the files are incorrect. Files may also be inaccessible if users manually manipulate the line printer system by bypassing the `lpr` program.

In addition to messages generated by `lpd`, any one of the filters that `lpd` creates may log messages using `syslogd` to the error file specified in the `lf` field of the `/etc/printcap` file.

---

## lpmv error messages

The following message is produced by the `lpmv` utility:

```
permission denied
```

A user attempted to move file(s) that are not owned by the user.

---

## lpq error messages

The following messages are produced by the `lpq` utility:

```
no space on remote; waiting for queue to drain
```

This message implies that there is insufficient disk space on the remote machine. If the file is large enough, there may never be enough space on the remote machine (even when the queue is empty). To correct this problem, move the spooling queue or create more disk space on the remote machine.

```
printer is ready and printing
```

The `lpq` utility checks to see if a daemon exists for *printer* and prints the status file located in the spooling directory. If the daemon is hung, use the `lpc` utility to abort the current daemon and start a new one.

```
sending to host
```

Files are being transferred to the remote machine *host*.

```
waiting for host to come up
```

This message implies that a daemon is trying to connect to a remote machine named *host* to send files in the local queue. Use the `/usr/etc/ping` command to see if the remote machine is up. If the remote machine is up, the daemon on the remote machine has probably died or is hung and must be restarted.

waiting for *printer* to become ready (offline?)

The daemon could not open the printer device. This happens for several reasons; the most common are that the printer is offline, powered off, or physically disconnected. Other possibilities are that the printer is out of paper or the paper is jammed. Not all printers supply enough information to indicate whether the printer is having trouble or is merely offline. The only way to tell what is actually wrong (without physically going to the printer) is through the error code returned by the device driver.

Another possible cause of this message is that a process, such as an output filter, has already opened the device and has died or is hung. If this is the case, you must kill the offending process and restart the printer with the `lpc` utility.

```
warning: no daemon present
```

The line printer daemon that controls the queue does not exist. This message occurs when the daemon has unexpectedly died. Check the error log file and the `syslogd` files for diagnostics from the daemon. To restart the daemon, enter:

```
% /etc/lpc restart printer
```

```
warning: printer is down
```

The printer has been made unavailable by the `lpc` utility.

---

## lpr error messages

The following messages are produced by the `lpr` utility:

```
lpr: printer: jobs queued, but cannot start daemon
```

The connection to the line printer daemon, `lpd`, on the local machine failed. This usually means that the master printer daemon started during the boot process has died or is hung. To determine whether the daemon is running, enter:

```
% /etc/lpc status printer
```

You can also determine whether the daemon is running with the following command

```
% ps -ax | grep lpd | grep -v grep
```

If no `/usr/lib/lpd` process is displayed, restart the daemon using the `lpc restart printer` command:

```
% /etc/lpc restart printer
```

or enter

```
% /usr/lib/lpd
```

Another possibility is that the `lpr` program does not have its owner and group set to `daemon`, or the `setuid` and `setgid` are not set. This can be checked with the command:

```
% ls -lg /usr/ucb/lpr
```

The following should be displayed if everything is set correctly:

```
-rwsr-sr-x 1 lpr lpr 124725 Jun 29 16:57 /usr/ucb/lpr
```

```
lpr: printer: printer queue is disabled
```

The printer queue is disabled. Jobs can be sent to the queue, but nothing will be printed until the queue is enabled with the command:

```
% /etc/lpc enable printer
```

```
lpr: printer: unknown printer
```

The `printer` was not found in the `printcap` file. Usually this is a typing mistake; however, it may indicate a missing or incorrect entry in the `/etc/printcap` file.

---

## **lprm error messages**

The following message is produced by the `lprm` utility.

```
lprm: printer: cannot restart printer daemon
```

The connection to the line printer daemon, `lpd`, on the local machine failed. This usually means that the master printer daemon started during the boot process has died or is hung. To determine whether the daemon is running, enter:

```
% /etc/lpc status printer
```

You can also determine whether the daemon is running with the following command

```
% ps ax | grep lpd | grep -v grep
```

If no `/usr/lib/lpd` process is displayed, restart the daemon using the `lpc restart` command

```
% /etc/lpc restart printer
```

or enter

```
% /usr/lib/lpd
```

Another possibility is that the `lprm` program does not have its owner and group set to `daemon`, or the `setuid` and `setgid` are not set. This can be checked with the command

```
% ls -lg /usr/ucb/lprm
```

The following message will be displayed if everything is set correctly:

```
-rwsr-sr-x 1 lpr lpr 147982 Jun 29 16:57
/usr/ucb/lprm
```

---

# Recovering from disk failure

# B

---

## Device failure messages

This appendix explains messages issued by the Virtual Volume Manager (VVM) and appropriate responses to those messages. VVM always sends a message to the console when a device fails. If the state or configuration of your system requires operator-assisted reconstruction, VVM issues additional messages to that effect.

On detection of a failed device, VVM prints the following messages to the console:

```
failure: device /dev/dxxx in stripe /dev/stx
failed
the mvst(8) command to perform the given
reconstruction has begun execution
```

After printing the device failure message to the console, VVM attempts to instruct its daemon, `vvmdaemon`, to begin the automatic reconstruction process. Automatic reconstruction involves using parity or mirrored data to reconstruct data from the failed disk device onto a previously allocated hot spare.

If VVM successfully contacts the daemon, and the daemon is able to perform the reconstruction, no human intervention is required. VVM prints the following message to the console, then places start and finish notifications in the daemonlog:

```
failure: mvst(8) command completed
successfully
the mvst(8) command successfully completed
its task
```

---

## Disk and machine failure

If your machine crashes at the same time a disk fails, the failure indication may not be written to `/etc/stripecap`. In this case you *must* reconstruct the failed disk data before booting to multiuser mode to prevent losing the data.

Refer to Chapter 10 for the procedure to follow if this situation occurs.

---

## Messages requiring operator action

If no hot spare is available, VVM sends the following message to the console:

```
unable to replace device /dev/dxxx in
/dev/stx
this must be done manually with mvst(8)
```

If VVM is unable to contact the daemon, or the daemon is unable to perform the reconstruction, VVM sends the following message to the console:

```
failure: mvst(8) exited with an error
correct the problem and restart the mvst(8)
command manually
```

In the case of any of the above messages, use the `mvst` utility to reconstruct the lost data. Use the procedure described in the following section, "Manual reconstruction".

## Manual reconstruction

Follow these steps to reconstruct data from a failed disk:

**Step 1** Log in as root.

Because different partitions of the same disk may be included in separate stripes, first determine which stripe(s) included partitions from the failed disk.

**Step 2** Enter:

```
% qst disk_device
```

*disk\_device* is the name of the failed disk. `qst` returns all stripes that used that disk. For example, suppose `/dev/du4` failed. Then

```
% qst /dev/du4
```

returns

```
 /dev/du4h is used in /dev/st1 (non-redundant)
 /dev/du4e is used in /dev/st3 (redundant)
```

Perform the following steps for each partition on the failed disk that was part of a redundant stripe. If console messages indicated no suitable hot spare is available, skip to Step 4.

**Step 3** Determine whether a suitable hot spare disk is available. Enter

```
% getst -H
```

to view the list of available hot spares. For each hot spare, `getst` returns the amount of space it contains, the stripes (if any) for which it has an affinity, and the locations where the spare partition is used. Figure 61 shows example `getst` output.

Figure 61 Sample `getst` output

```
% getst -H
hot spare hs0: du9a (64, 2305), sector size 2048 bytes, length 49200 Kbytes
 49200 Kbytes used [100%]
 affinity towards st0
 space in use by st0
hot spare hs1: du6f (64, 1542), sector size 2048 bytes, length 196800 Kbytes
 49200 Kbytes used [25%]
 affinity towards st1
 space in use by st1
```

If a suitable hot spare is available, skip to Step 5.

**Step 4** Find an available disk partition (use of the C partition is recommended) that qualifies as a hot spare for the stripe containing the failed disk. To qualify as a hot spare, a partition must have the following qualities:

- Sector size less than or equal to the sector size of the stripe device to be replaced
- Space greater than or equal to that of the partition to be replaced
- Not already used in a stripe with the failed disk
- Same disk type as the failed disk (preferable, but not mandatory)

**Step 5** If a hot spare was available, reconstruct data from the failed disk onto the hot spare. Enter

```
% mvst -H /dev/stx /dev/d???
```

where *stx* is the stripe containing the failed disk and *d???* is the device number of the hot spare partition. If a hot spare was not available, enter

```
% mvst /dev/stx /dev/dbad /dev/d??? xxx-yyy
```

where *stx* is the stripe containing the failed disk, */dev/dbad* is the device number of the failed disk, and */dev/d???* and *xxx-yyy* are the device number and device type of the available disk partition that you found in Step 4.

---

## Restarting vwm Daemon

Reconstruction is now complete. If hand reconstruction was required because VVM could not contact `vwm Daemon`, you may wish to check for the presence of `vwm Daemon` and restart it if it is not running. To do so, complete the following steps:

**Step 1** Enter:

```
% ps aux | grep vwm Daemon
```

**Step 2** If `vwm Daemon` is not running, enter

```
% vwm Daemon
```

to start it.

---

# Reporting problems



The CONVEX Technical Assistance Center (TAC) is staffed by technical specialists who can address diverse questions and problems arising in a supercomputing environment. The TAC recommends using the `contact` utility to inquire about hardware, software, or documentation. `contact` is an interactive program that helps the TAC track reports and route them to the CONVEX personnel most qualified to handle them.

This appendix describes:

- Prerequisites for using `contact`
- Tips for using `contact`
- Step-by-step procedure for using `contact`

---

## Prerequisites for using `contact`

The `contact` utility requires:

- UNIX-to-UNIX Communication Protocol (UUCP) connection to the TAC
- Full path name of the program or utility about which you have an inquiry
- Version number of the program or utility about which you have an inquiry

---

## UUCP connection

Before using `contact`, ask your system manager if your site has a UUCP connection to the TAC. A UUCP connection allows files to be copied from one UNIX-based system to another. The `uucp` (UNIX-to-UNIX copy) command relies on either a dial-up or hard-wired UUCP communication line.

---

## Using `which` to find a program's path name

To determine the full path name a program or utility, use the `which` command, which has the following syntax:

```
which program
```

*program* is the name of the program whose path you need. Figure 62 illustrates the use of `which` to find the full path name of a fictitious program called `filefix`.

**Figure 62** Using the `which` command

```
% which filefix
/bin/filefix
% █
```

In this example, the full path name of `filefix` is `/bin/filefix`.

If you use `csh` or `ksh`, you can use the `whence` command to find a program path name instead. `whence` works the same as `which`, but faster.

For more information on the `which` or `whence` command, refer to the `which(1)` or `whence(1)` man page, respectively.

---

## Using `vers` to find a program's version number

To determine the version number of a program or utility, use the `vers` command, which has the following syntax:

```
vers path
```

*path* is the full path name of the program or utility whose version number you need. Figure 63 illustrates the use of `vers` to find the version number of the program `filefix`.

**Figure 63** Using the `vers` command

```
% vers /bin/filefix
/bin/filefix: 10.0
% █
```

In this example, the version number of `filefix` is shown to be 10.0.

For more information on the `vers` command, refer to the `vers(1)` man page.

---

## Tips for using contact

This section lists tips to help you use `contact` efficiently. In particular, this explains:

- Creating a `.contact` file
- Suspending a `contact` session
- Moving within `contact` from one prompt to another
- Using tilde-escape sequences within `contact`
- Aborting your `contact` report
- Submitting your aborted report

---

### Creating a `.contact` file

When you invoke `contact`, it first prompts for your name, title, phone number, and company name. You can, however, create a `.contact` file to skip this first prompt. `contact` will look for a `.contact` file and use the information in that file automatically.

Follow these steps to create a `.contact` file:

1. Create a `.contact` file in your home directory.
2. Enter your name, job title, phone number, and company name, each on a new line.

In Figure 64 is an example of a `.contact` file viewed using the `cat` command

**Figure 64** Example of a `.contact` file (viewed with the `cat` command)

```
% cat .contact
Chris Smith
Programmer
(214) 900-2000
Jupiter Corporation
% █
```

---

### Suspending your `contact` session

Sometimes it is necessary to suspend your `contact` session and return to your shell (for instance, to find your program path name or version number). To suspend your `contact` session, press `CTRL-z`.

To return to the `contact` session, type `fg`. Using `CTRL-z` and the `fg` (foreground) command, you can switch between `contact`

and your shell. You cannot, however, use **CTRL-z** and **fg** to switch back and forth if you use Bourne shell (**sh**).

---

## Moving to another prompt

The `contact` utility prompts for information pertinent to your hardware, software, or documentation question. Some prompts require one-line responses; to move to the next prompt, press **RETURN**. Other prompts require more than a one-line response; to move to the next prompt, press **CTRL-d**.

---

## Tilde-escape sequences

The `contact` utility treats input beginning with a tilde (~) as a special sequence. The character following the tilde is considered a request for a special function.

You cannot use tilde-escape sequences when listing file names to include in your report, as described in Step 11 on page 169.

Any other time you can use the following tilde sequences within `contact`:

- `~e` Edit your report using your default editor (defined in your `EDITOR` environment variable)
  - `~h` Help by displaying a list of available tilde-escape sequences
  - `~p` Print your `contact` report to the terminal screen
  - `~r filename` Read the contents of a specified file into a response to the current prompt, where *filename* is the name of the file you wish to specify.
- Some prompts require only a one-line response. This tilde-escape sequence works only for prompts that allow more than a one-line response.
- `~~` Insert a single tilde as the first character in the line. This is in case you need to use a tilde as part of your response and not as an escape sequence.

---

## Aborting your report

To abort a `contact` report, either press the interrupt key (usually **CTRL-c**) or choose the `abort` option when prompted by the `contact` utility as described in Step 12 on page 170. Using **CTRL-c** to abort does not save the contents of the report. Using the

`abort` option saves the contents of the report in a file named `~/dead.report`.

---

### **Submitting your `dead.report` file**

After you abort a `contact` report (using option 4, as shown in Step 12 on page 170), `contact` saves the report in a file named `~/dead.report`. If you specify the `-r` option when you next invoke `contact`, it automatically merges the contents of the `~/dead.report` file from your previous report into your current `contact` report. For more information on how to use the `-r` option, refer to Step 1 on page 165.

---

## Using contact

Before using `contact`, refer to the previous section, "Prerequisites for using `contact`," which gives you important information you must know in order to use `contact` effectively.

### Step 1 Invoke `contact`.

The `contact` utility has the following syntax:

```
contact option
```

where *option* can only be

`-r`

which includes the `~/contact.dead` file of your previous report with your current `contact` report. For more information on this option, refer to the section, "Creating a `.contact` file," on page 162.

`contact` can be invoked as shown in Figure 65.

**Figure 65** Beginning a `contact` report

```
% contact
Welcome to contact version 0.12 (90/02/05)
```

After invoking `contact`, the system responds with a welcome message and a series of questions regarding your hardware, software, or documentation question. To use `contact` effectively, you must then provide the following information:

1. Your name, title, phone number, and corporate name.
2. Name of the product with which you are having a problem.
3. Version number of the product with which you are having a problem.
4. One-line summary of the problem.
5. Detailed description of the problem.
6. Priority of the problem.
7. Instructions on how to reproduce the problem.
8. Comments about the problem.
9. Comments about the documentation relating to the problem.
10. Whether files are included in the `contact` report and, if so, the full path names of these files.
11. How you would like to complete your `contact` session.

**Step 2** Enter information about yourself.

After invoking `contact` you are asked for some information about yourself, as shown in Figure 66, unless you have a `.contact` file in your home directory. If you have a `.contact` file in your home directory, `contact` skips this inquiry. (Refer to the section, "Creating a `.contact` file," on page 162)

Figure 67 illustrates how to invoke `contact` and how the system responds if you have a `.contact` file in your home directory. If you have a `.contact` file, go to Step 3.

**Figure 66** Beginning a `contact` report without a `.contact` file

```
% contact
Welcome to contact version 0.12 (90/02/05)

Enter your name, title, phone number, and corporate name (^D to terminate)
> Chris Smith
> Programmer
> (214) 900-2000
> Jupiter Corporation
> ^D
```

**Step 3** Enter the product name.

The `contact` utility next prompts for the name of the product with which you are experiencing a problem, as shown in Figure 67. Enter the name of the product.

**Figure 67** Beginning a `contact` report with a `.contact` file

```
% contact
Welcome to contact version 0.12 (90/02/05)

Enter the name of the product involved
> filefix
```

**Step 4** Specify a program version number.

The `contact` utility prompts for the version number of the product with which you are experiencing a problem, as shown in Figure 68.

Figure 68 Prompt for product version number

```
Enter the version number (in the form X.X or X.X.X.X) of the product
> 9.0
```

If you do not know the version number, press **CTRL-Z** to suspend the session and refer to the section, "Using vers to find a program's version number," on page 161. After you have determined the proper version number, use the **fg** command to return to the contact session and enter the version number in the form *X.X* or *X.X.X.X*, such as

```
9.0
```

or

```
9.0.0.1
```

**Step 5** Enter a one-line problem summary.

The contact utility prompts for a one-line summary of the problem, as shown in Figure 69.

Figure 69 Prompt for a short problem summary

```
Enter a short (1 line) summary of the problem
> Trouble suspending filefix
```

This summary is the subject header in any further correspondence regarding your problem. Please make this summary as descriptive as possible in one line.

**Step 6** Enter a detailed problem description.

The contact utility prompts for a detailed description of the problem, as shown in Figure 70.

Figure 70 Prompt for a detailed description of the problem

```
Enter a detailed description of the problem (^D to terminate)
> After entering filefix, I have trouble suspending the session if I want to do other tasks.
> ^D
```

Enter a detailed description of the problem. When you have completed your description, press **CTRL-d**.

When writing your problem description, please make it as complete as possible. Include source code and a stack backtrace when possible. (Refer to the `adb(1)` or `csd(1)` man pages for

information on obtaining a stack backtrace.) The more information you provide, the quicker the TAC can isolate and solve your problem.

**Step 7** Enter a problem priority.

contact prompts for the priority of your problem. The priority of a problem indicates the impact your problem has on your work. Figure 71 shows how contact prompts for priority levels. Select your problem priority by entering the number associated with the priority.

You must enter the number associated with your problem priority.

**Figure 71** Prompt for problem priority

```
Enter a problem priority, based on the following:
1) Critical - work cannot proceed until the problem is resolved.
2) Serious - work can proceed around the problem, with difficulty.
3) Necessary - problem has to be fixed.
4) Annoying - problem is bothersome.
5) Enhancement - requested enhancement.
6) Informative - for informational purposes only.
> 4
```

**Step 8** Give instructions how to reproduce the problem.

contact prompts for instructions on how to reproduce the problem, as shown in Figure 72.

**Figure 72** Prompt for instructions on how to reproduce the problem

```
Enter instructions by which the problem may be reproduced (^D to terminate)
> 1. Enter filefix myfile.c
> 2. Suspend by entering CTRL-s
> ^D
```

Please include the command syntax and options you used and anything else you did to make the program run.

**Step 9** Give applicable comments.

The contact utility prompts for any other pertinent comments, as shown in Figure 73. Please include all relevant information.

**Figure 73** Prompt for additional, applicable comments

```
Enter any comments that are applicable(^D to terminate)
> Perhaps I am using the wrong command?
> ^D
```

**Step 10** Offer suggestions for documentation and support.

The `contact` utility prompts for suggestions regarding documentation supporting the product, as shown in Figure 74.

**Figure 74** Prompt for suggestions or comments

```
Do you have any suggestions or comments on the documentation that you
referenced when you were trying to resolve your problem (for example,
additions corrections, organization, accessibility)? (^D to terminate)
> A command summary or quick-reference for filefix would be helpful.
> Documentation could be revised for this.
> ^D
```

Please indicate whether the documentation could be revised to address the problem.

**Step 11** Indicate additional files.

The `contact` utility prompts for names of files necessary to reproduce the problem.

If you have files that can be included with your report, enter "yes" and enter the related file names, as shown in Figure 75.

List file names one per line. After entering your last file name, press `CTRL-d`. Tilde-escape sequences are not recognized in your file listing. A tilde (~) in this section indicates your home directory.

**Figure 75** Including additional files in your contact report

```
Are there any files that should be included in this report (yes | no)?
> yes
Please enter the names of the files, one to a line (^D to terminate)
> myfile.c
> ^D
```

If you do not have any files to include with your report, enter "no," and you will be prompted for the next response.

If files specified are small text files, they are automatically included in the contact report. If the files are too large to be

included in this report, `contact` gives further instructions on how to submit these files.

To specify a directory, combine directory files into a single file using the `tar` command (refer to the `tar(1)` man page for further information) or enter each file name in the directory on a single line in the `contact` report.

**Step 12** To finish your `contact` report, you are given the choice to review, edit, submit, or abort the report, as shown in Figure 76.

You must enter the number associated with your selection.

**Figure 76** Prompt to review, edit, submit, or abort your `contact` report

```
Please select one of the following options:
1) Review the problem report.
2) Edit the problem report.
3) Submit the problem report.
4) Abort the problem report.
> 3
```

The options listed in Figure 76 indicate the following:

- |        |                                                                                                                                                                                                        |
|--------|--------------------------------------------------------------------------------------------------------------------------------------------------------------------------------------------------------|
| Review | Review the text of the <code>contact</code> report. You are then prompted again to select an option.                                                                                                   |
| Edit   | Edit the text of the <code>contact</code> report. If you choose to edit the report, <code>contact</code> opens your default text editor.                                                               |
| Submit | Send the report to the CONVEX TAC. The TAC notifies you within 48 hours that your report has been received. Choosing this option exits the <code>contact</code> utility and returns you to your shell. |
| Abort  | Save the text of the report in a file named <code>~/dead.report</code> (in your home directory). Choosing this option exits <code>contact</code> and returns you to your shell.                        |

# Master index

This index covers four books. Prefixes with the page numbers in each index entry indicate the book in which the related information can be found. Prefixes are associated with individual books in the following way:

|    |                                               |
|----|-----------------------------------------------|
| CO | <i>Managing ConvexOS: Configuration Guide</i> |
| OP | <i>Managing ConvexOS: Operations Guide</i>    |
| TM | <i>ConvexOS Tape System Manager's Guide</i>   |
| TO | <i>ConvexOS Tape System Operator's Guide</i>  |

## A

abspathlen, CPU boot-time parameter CO-290

Accelerate\_enable, CPU boot-time parameter CO-302

access

changing access to files using chmod CO-10

default file CO-8

permissions CO-6, CO-10

protecting

access to files CO-6

protecting login CO-4

protecting physical access to system CO-2

protecting UUCP or dial-in access to system CO-3

access drive list

add groups TM-113, TM-115, TM-117, TM-120,

TM-122, TM-124, TM-127, TM-129, TM-131

add users TM-114, TM-116, TM-118, TM-121, TM-123,

TM-125, TM-128, TM-130, TM-132

adding TM-113

creating TM-113

deleting from TM-115, TM-117

replacing TM-115

access-template file CO-247

accounting reports OP-55–OP-76

automatic generation OP-58

bill command OP-56

connecttime command OP-66–OP-67

convert ids OP-75

disk use data OP-73

generating OP-55

information collection OP-56

log files OP-56

login data OP-66–OP-67

logout data OP-66

manual generation OP-60

printer use data OP-70, OP-72

printer user data OP-70

process termination data OP-60, OP-62, OP-64

reboot data OP-66

scripts OP-58

sorting data OP-75

summary utilities OP-60

tape use data OP-68

accounting system

activities CO-182

activities file CO-186

activity codes CO-186

add activities CO-186

add group/activity combinations CO-187

bill command CO-182

billing accounts CO-182

billing accounts, default CO-189

collecting information OP-56, CO-182, CO-189

CXbatch CO-186, CO-190

described CO-182

line printer system CO-135

log files CO-184

printcap CO-184, CO-189

reports, see accounting reports

setting up CO-181

start CO-189

accounts, user, see user accounts

acct file CO-184, CO-348

acct system call CO-348

accton command CO-189

ACL CO-40, TM-143

ACS (Automated Cartridge System) TO-71

adding TLI drives to TM-149

command list TM-148, TO-72

dismounting a cartridge with TM-168, TO-90

drive coordinates TM-149, TO-73

ejecting cartridges from TM-166, TO-88

entering cartridges into TO-85

entering cartridges into TM-163

mounting a cartridge with TO-89

- reporting component status TO-74
- reporting status TM-154
- requirements TM-147
- setting environment variable for TM-148, TO-72
- status reporting TO-76
- active system CO-144–CO-150, CO-151, CO-156, CO-156–CO-157
- activities file CO-186, CO-350
- activity
  - ID CO-350
  - monitoring pending UUCP CO-26
  - names CO-350
- actwho file CO-187, CO-351
- adding
  - 9-track drives TM-84
  - access drive list TM-113
  - cartridge drives TM-84
  - DAT drives TM-84
  - disks CO-35, CO-80
  - extra security measures TM-133
  - group membership CO-177
  - label tapes TM-105
  - many nodes to a tape drive TM-92
  - modems CO-21, CO-45, CO-46
  - new label type TM-107
  - nodes to a defined tape drive TM-88
  - plotters CO-21, CO-62
  - printers CO-21, CO-59
  - stacker/loader to your system TM-144
  - terminals CO-37
  - TLI drives to the ACS TM-149
  - to allocate drive list TM-120
  - to bypass label list TM-127
- users
  - in batch mode CO-170
  - interactively CO-167
  - manually CO-172
- adding devices TM-83
- adding nodes TM-84
- adding tape drives TM-83, TM-84
- aliases CO-353
  - database
    - problems during rebuild OP-87
    - rebuilding OP-87
- aliases, sendmail CO-204–CO-210
  - command line CO-205
  - database
    - rebuilding CO-210
    - using an alternate filename CO-210
    - using NIS aliases map CO-210, CO-237
  - filename CO-205
  - inclusion CO-206
  - list owner CO-207
  - list request CO-207
  - MAILER-DAEMON CO-207
  - nobody CO-208
- aliasing loops CO-208

- allocate drive list
  - adding to TM-120
  - creating TM-120
  - deleting from TM-124
  - replacing TM-122
- ansidaemon TM-6
- assigned*, title bar label TO-14
- associated documents OP-xix
- at command OP-32–OP-33
- auto\_nice\_factor, CPU boot-time parameter CO-290
- auto\_nice\_threshold, CPU boot-time parameter CO-290
- autologout option CO-2
- Automated Cartridge System, *refer to ACS*
- automatic report generation, accounting OP-58
- Auto-Vol-Rec opreq message type TO-15
- avail
  - activating CO-261–CO-262
  - avail.conf file CO-261–CO-263
  - command CO-261–CO-263
  - description CO-261
- avail.notes file CO-250
- availlog CO-261
- AVR (Automatic Volume Recognition) TO-36, TO-44, TO-46, TO-47

---

## B

- backing up files CO-120, TO-54
  - archive schedule CO-126
  - dump level CO-123
  - full backup CO-123
  - incremental backup CO-123
  - planning schedule CO-122
  - scripts CO-126
- backups, performing TO-53–TO-69
- batch mode, using tponfig in TM-71
- bill command OP-56, CO-182–CO-183, CO-351, CO-354
- bill\_acct file CO-354
- bill-errs file OP-56, OP-66, CO-184, CO-188, CO-354
- bill-errs file OP-56, OP-61, CO-184, CO-188
- block
  - device CO-79, CO-103
  - size CO-66, CO-83, CO-96
- block special device files CO-30
- boot single command OP-147
- bootcmd file CO-288
- bootcmd.local file CO-288
- boot-time parameters CO-290–CO-302
  - changing CO-289
  - CPU parameters CO-290–CO-302
  - MIOF parameters CO-302
  - setting CO-289
  - STREAMS tunable parameters CO-303
- buffer cache CO-82

- buffered I/O CO-16
  - syspic window CO-16
- bus CO-25
- bypass label list TM-129
  - adding to TM-127
  - creating TM-127
  - deleting from TM-131
- bypassing
  - ConvexOS tape system TM-167, TM-168, TO-89, TO-90
  - label restrictions TO-51
- bypassing label permissions TM-126

## C

- ca\_timer\_code, CPU boot-time parameter CO-302
- Cancel opreq message status TO-14
- CAP (Control Access Port) TO-74–TO-77
  - status reporting TO-77
- cat command CO-270
- cat\* directories CO-269
- catman utility CO-268
- Cautions
  - carefully choose commands for the L.cmds file CO-159
  - changes to the ioconfig file CO-86
  - changing the order of entries in ioconfig file CO-86
  - Contact the TAC before modifying CSR and interrupt parameters CO-26
  - Contact the TAC before modifying values in /etc/disktab. CO-36
  - crash dump must be taken before rebooting OP-131
  - do not execute hardware dump before running crashdump OP-133
  - do not execute standalone hardware dump OP-133
  - Do not overlap partitions assigned to same area CO-68
  - file system corruption OP-97
  - newst destroys data CO-109, CO-111
  - overlapping partitions CO-68
  - performing crashdumps before rebooting OP-131
  - setting up UUCP over Ethernet CO-143
  - the newfd command destroys data CO-105
  - the on command CO-42
  - use vipw to edit /etc/passwd and /etc/pwrestrict files CO-173
  - using mvst -nv before issuing mvst command OP-52
- CCPU boot-time parameter
  - max\_swapout CO-300
  - swap\_nicehg CO-301
  - tty\_iop\_size CO-298
- CCU busy, syspic window CO-16
- chall command CO-137, CO-176
- changing process priorities OP-29
- changing tapes with opreq TO-45

- Channel Control Unit (CCU)
  - and /ioconfig file CO-22
  - description CO-24
  - supported types CO-24
- character special device files CO-30, CO-43
- chgrp command CO-147
- chmod command CO-10–CO-11, CO-285
- chown command CO-147
- clean\_direntry, CPU boot-time parameter CO-291
- collection log files CO-184
- commands, also see utilities
- command output
  - tpconfig show all TM-77
  - tpconfig show de TM-78
  - tpconfig show dr TM-81
  - tpconfig show labels TM-79
  - tpconfig shownode TM-82
- commands OP-84
  - accton CO-189
  - ACS TM-148, TO-72
  - at OP-32–OP-33
  - bill OP-56, CO-182–CO-183
  - boot single OP-147
  - cat CO-270
  - chall CO-137, CO-176
  - chgrp CO-147
  - chmod CO-10, CO-285
  - chown CO-147
  - configure-drives TO-24
  - configure-drives (opreq) TO-24
  - configure-status (opreq) TM-138, TO-16, TO-22
  - configure-title (opreq) TM-138, TO-12, TO-22
  - configure-type (opreq) TM-138, TO-18, TO-22
  - connecttime OP-61, OP-66
  - contact OP-165
  - cpureg OP-134, OP-137, OP-141
  - crashdump OP-134
  - crypt CO-17
  - df CO-23, CO-86, CO-99, CO-114, CO-192
  - diskuse OP-60, OP-73
  - du CO-23–CO-24
  - dump CO-120, CO-275, CO-277
  - edactwho CO-187
  - edquota CO-193
  - faillogon CO-253, CO-257
  - faillogpr CO-256
  - fg OP-162, OP-167
  - field TO-9
  - field-comment TO-26, TO-38, TO-40, TO-45
  - field-vsn TO-26, TO-38, TO-46
  - find CO-178
  - fsck OP-103–OP-106, CO-114
  - getst OP-53, OP-147, CO-75, CO-88
    - sample output OP-157
  - grep CO-150
  - help TM-73
  - kill CO-260, CO-285

lastcomm OP-60  
lpc CO-137  
lpc enable CO-137  
lpc restart CO-137  
lpd OP-151  
lpmv OP-48, OP-151  
lpq OP-47, OP-151  
lpr OP-37, OP-153  
lprm OP-49, OP-154  
ls CO-7  
mailq OP-84  
MAKEDEV TM-90  
man CO-267  
mkdir CO-176  
mount OP-52  
mvst OP-52, OP-148, OP-158  
newaliases OP-87  
newfs CO-106  
newst OP-54, CO-74, CO-92, CO-109  
nfsaccess CO-248  
nice OP-30  
nu CO-169, CO-172  
op OP-1, CO-284  
osclean OP-134, OP-137, OP-141  
pac OP-60, OP-61, OP-71  
passwd CO-176  
ping OP-151  
preen OP-103, OP-107, OP-148, CO-115, CO-316  
ps CO-8–CO-9, OP-30  
qst OP-54, OP-147, OP-157  
quota CO-23, CO-25  
quotacheck CO-194  
quotaon CO-194  
rdump CO-120, TO-56, TO-61  
reboot CO-117  
renice OP-31  
restore TO-64, TO-67  
rmst OP-54  
rrestore TO-64, TO-67, TO-68  
ruptime CO-7  
sa OP-62  
select\_cancel TM-140  
select\_done TM-140  
select\_work TM-140  
select-cancel TO-26  
select-done TO-26  
sendmail OP-79–OP-87, CO-240  
set list CO-130  
set queueing enabled TM-141  
setenv SILOHOST TM-148, TO-72  
show nodes TM-175, TO-101  
shutdown CO-113, CO-290, CO-315  
silodismount TM-148, TM-168, TO-71, TO-90  
siloeject TM-148, TO-71, TO-88  
silointer TM-148, TM-163, TO-71, TO-85  
silomount TM-148, TO-71, TO-89  
silquery TM-148  
  
spu CO-22, CO-84  
spu -r CO-289  
spu -w CO-290  
strip CO-14  
syspic CO-6, CO-12, CO-19–CO-22  
tellcron OP-35  
telnet CO-244  
touch CO-193, CO-253, CO-260  
tpattr TO-60, TO-67  
tpconfig TM-75  
tpconfig add access\_drive TM-112  
tpconfig add drive TM-87  
tpconfig add label TM-107  
tpconfig add node TM-90  
tpconfig add stacker TM-144  
tpconfig del stacker TM-146  
tpconfig delete access\_drive TM-112  
tpconfig se d dr mt TM-100  
tpconfig set access\_drive TM-112  
tpconfig show all TM-77  
tpconfig show de TM-78  
tpconfig show drives TM-173, TM-175, TO-99,  
TO-100  
tpconfig show labels TM-106, TM-172, TO-97  
tpconfig show nodes TM-174, TO-100  
tpconfig show stackerdaemon TM-145  
tpconfig snapshot TM-72  
tplabel TO-60  
tpmount TO-51, TO-55, TO-59, TO-63, TO-66  
tpqueue TM-175, TM-177, TO-101, TO-103  
tpunmount TO-55, TO-57, TO-59, TO-62, TO-63,  
TO-66  
umask CO-9, CO-15  
update CO-114  
uptime CO-6  
uucico CO-157  
uuclean cron CO-27  
uulook CO-26  
uumount OP-52  
uusnap CO-26  
verify OP-150  
vers OP-161  
vmstat CO-10  
vsn TO-40  
vmdaemon OP-158  
weekly CO-277  
whence OP-160  
which OP-160  
window-open (opreq) TM-138, TO-22  
xdump CO-120, TO-56, TO-60  
*comment*, title bar label TO-14  
config.db file TM-67  
configuration information  
obtaining with tpconfig TM-76  
configure-drives command TO-24  
configure-status command TM-138, TO-22  
configure-title command TM-138, TO-22

- configure-type command TM-138, TO-18, TO-22
- configuring
  - disk partitions CO-100
  - modem connections CO-144
  - single disk partitions CO-104
  - striped partitions CO-108
  - swap space CO-93
  - system message logging CO-258
- configuring opreq
  - disabling a tape drive TO-24
  - displaying messages according to
    - status TO-16
    - type TO-18
  - setting screen defaults for all your sessions TM-138, TO-22
  - title bar TO-12
  - two-screen display example TM-139, TO-23
  - window defaults TO-20
- connectivity checking OP-122
- connecttime command OP-61, OP-66
- .contact file OP-162
- contact OP-160–OP-163
  - aborting reports OP-163
  - dead.report file OP-164
  - escape sequences OP-163
  - inquiries, summary of OP-165
  - invoking OP-165
  - prerequisites OP-160–OP-161
  - suspending OP-162
- contact utility CO-319
  - local delivery only CO-326
  - network delivery CO-325
- control status
  - resetting TM-97
- control store register (CSR) CO-26, CO-27
- controller
  - and /ioconfig file CO-22
  - and /ioconfig designations CO-403
  - description CO-26
  - IDC type CO-28
  - IOP type CO-26, CO-28
  - VIOP type CO-26, CO-28
- controlling
  - printers OP-40–OP-45
  - processes OP-29–OP-35
- CONVEX ACS
  - configuring TM-147, TM-149
- ConvexOS
  - bypassing tape system TO-89, TO-90
- ConvexOS file system CO-69
- ConvexOS, cat\* directories shipped with CO-268
- coordinates for ACS drives TM-149, TO-73
- CPU
  - activity, monitoring CO-10
  - usage CO-18
  - usage, syspic window CO-18
  - use, monitoring CO-6
  - use, monitoring current CO-25
- CPU boot-time parameter CO-292
  - abspathlen CO-290
  - Accelerate CO-302
  - auto\_nice\_factor CO-290
  - auto\_nice\_threshold CO-290
  - ca\_timer\_code CO-302
  - clean\_direntry CO-291
  - dmon\_enable CO-291
  - dst\_algorithm CO-291
  - enable\_unique\_core CO-291
  - erase\_pattern CO-291
  - erase\_unlink CO-292
  - gateway CO-292
  - getnewbuf\_goal CO-293
  - ipforwarding CO-293
  - ipsendredirects CO-293
  - logresume CO-293
  - logsuspend CO-294
  - max\_swapout CO-294
  - max\_user\_processes CO-294
  - maxregions CO-294
  - maxusers CO-294
  - min\_swapout CO-300
  - miniroot on CO-294
  - nfs\_portmon CO-295
  - nstbuf CO-295
  - number\_ptys CO-295
  - number\_ta\_iop\_wndw CO-295
  - number\_tty\_controllers CO-295
  - pgout\_macrss CO-296
  - pgout\_maxscan CO-296
  - pgoutgoal\_rssdic CO-296
  - sendmsg\_access\_rights CO-296
  - stripe\_devices CO-296
  - subnetsareloca CO-297
  - suid\_shell\_script CO-297
  - swap\_pagerate CO-300
  - swap\_partswpchg CO-301
  - swap\_restimechg CO-301
  - swap\_rsschg CO-301
  - sys\_mask CO-297
  - ta\_force\_EOF\_on\_close CO-297
  - tickadj CO-298
  - time\_zone CO-298
  - tr\_nrecs CO-298
  - tty\_pty\_size CO-298
  - tty\_viop\_size CO-298
  - updcksum CO-299
  - viop\_enet\_proc CO-299
- CPU boot-time parameters CO-290–CO-302
- cpureg command OP-134, OP-137, OP-141
- crash dumps
  - recovering from system crashes OP-147
- crashdump utility OP-131–OP-145
  - Caution OP-131, OP-133
  - described OP-132

- example comment OP-135, OP-138, OP-142
- example error OP-145
- example mount tape prompt OP-136, OP-140, OP-142
- example output on start OP-135, OP-141
- hardware dump OP-133
- labelling tapes OP-136
- performing OP-131
- restarting OP-145
- tape drive options OP-133
- to a local tape drive OP-133
- two methods for taking OP-133
- using OP-133
- creating
  - access drive list TM-113
  - allocate drive list TM-120
  - bypass label list TM-127
  - filters CO-140
  - indexes for sourcing man pages CO-272
  - op.access file CO-282
  - search database for man pages CO-270
- cron utility CO-27, OP-35, CO-355, CO-393
- crontab
  - and UUCP CO-159
- crontab file OP-35, CO-160, CO-249, CO-355
  - and accounting reports OP-58
  - and logging CO-254, CO-262
  - and notesfiles CO-249
  - and scheduling processes OP-34
- crontab script CO-159
- crypt command CO-17
- .cshrc CO-165, CO-166
- CXbatch
  - and accounting CO-190
- cylinder groups OP-96
  - fsck checking OP-127, OP-128

---

## D

- daemon
  - line printer OP-38, OP-43
  - opreq\_daemon TM-5
  - printer CO-137
  - syslog CO-260
  - tape label daemons TM-6
  - tpdaemon TM-5
- daemons
  - inetd TO-1
  - opreq TO-1
  - portmap TO-1
  - tape system TO-1
  - tpdaemon TO-1
- daily script OP-58
- DARPA Internet CO-369
- data blocks OP-94
- decrypting files CO-17
- default drive type

- setting TM-100
- default flags
  - setting TM-102
- default tape density
  - unsetting TM-101
- default user files CO-165
- defaults
  - displaying tape system TM-78
  - setting tape system TM-99
- defaults, displaying with tpconfig show de TM-78
- defaults, setting for your opreq window TO-20
- defined nodes
  - displaying information TM-82
- defined tape drive
  - adding nodes TM-88
- deleted files, erasing CO-16
- deleting
  - from access drive list TM-117
  - from allocate drive list TM-124
  - from an access drive list TM-115
  - from bypass label list TM-131
  - label types TM-105, TM-108
  - nodes from the tape system TM-94
  - stacker/loader from your system TM-146
  - tape drives from the tape system TM-94
- /dev/MAKEDEV CO-31
- /dev/null CO-12
- device drivers CO-305, CO-329
- device failure messages OP-155
- device file, mapping CONVEX to ACS drive coordinate TM-150
- device files CO-30, CO-103
  - and /ioconfig file CO-33
  - naming conventions CO-31
  - special CO-21
- device unit CO-28
- devices
  - /ioconfig file, see /ioconfig file
  - adding TM-83
  - adding a device CO-21
  - adding a disk CO-35
  - adding a terminal CO-37
  - description CO-28
  - disk naming conventions CO-34
  - for HSP controllers CO-29
  - for IDC controllers CO-28, CO-33
  - for IOP controllers CO-28
  - for VIOP controllers CO-28
  - gettytab file CO-39, CO-55
  - /ioconfig designations CO-403
  - modem CO-46
  - naming convention for disk CO-34
  - numbering CO-31
  - plotters CO-62
  - printers CO-59
  - pseudoteletype CO-295
  - pseudoterminals CO-43

- terminal naming conventions CO-38
- ttys file CO-43
- df command CO-23, CO-86, CO-99, CO-114, CO-192
- directories
  - public CO-12
  - sticky bit CO-12
- directory
  - .utilities CO-247
  - cat\* CO-269
  - idx\* CO-272
  - lost+found OP-102
  - lpd OP-38
  - public CO-12
  - sysgen CO-307
  - uucpublic CO-146
- directory data blocks OP-101
- disabling a tape drive with opreq TO-24
- disk CO-65
  - adding CO-21, CO-35, CO-80
  - devices
    - adding CO-35
    - naming conventions CO-34
  - disk space
    - mapping CO-66
  - disk striping CO-80
    - redundant CO-73
  - failure OP-156
    - manual reconstruction OP-157
    - messages that require operator action OP-156
    - recovery procedures OP-147, OP-155
    - restarting vvmdaemon OP-158
  - load balancing CO-80
  - manual reconstruction of failed OP-157
  - monitoring OP-51
  - naming conventions CO-79
  - partitioning CO-86, CO-100
  - partitions CO-67, CO-100
    - single CO-104
  - quotas
    - described CO-191
    - edquota file CO-193
    - fstab file CO-194
  - replacing in a stripe OP-52
  - space
    - monitoring current CO-25
    - monitoring free CO-23
    - monitoring limits CO-25
    - monitoring used CO-24
  - space use, setting quotas CO-191
  - striping CO-72, CO-88
  - system CO-65
    - changes, integrating CO-113
    - concepts CO-66
    - setting up CO-65
  - system, planning OP-155, OP-156, OP-157, OP-158, CO-82
  - use, monitoring CO-23

- use, summarizing data OP-73
- disk partitions, see stripe partitions
- diskbygrp.awk script OP-60
- diskbyusr.aw script OP-60
- diskmerge.awk script OP-60
- disktab file CO-36, CO-357
- diskuse command OP-60, OP-73
  - /diskuse directory CO-359
- dismounting a cartridge with ACS TM-168
- displaying
  - a comment sent by tape user TO-27
  - all tape system configuration info TM-76
  - field information TO-9
  - info on all defined nodes TM-82
  - info on all tape drive configurations TM-80
  - messages according to status TM-138, TO-16, TO-22
  - messages according to type TM-138, TO-18, TO-22
  - nodes associated with a drive TM-93
  - opreq information TO-8
  - tape system configuration TM-74
  - valid label types TM-79
  - VSNs in a tape set TO-28
- displaying printer queue OP-38
- displaying tape system defaults TM-78
- dmon\_enable, CPU boot-time parameter CO-291
- Done opreq message status TO-14
- downtime, scheduling printer OP-45
- drive, title bar label TO-14
- driver
  - description CO-26
  - HSP type CO-27
  - IDC type CO-27
  - /ioconfig designations CO-403
- drivers
  - listing available TO-8
- dst\_algorithm, CPU boot-time parameter CO-291
- du command CO-23–CO-24
- dump
  - level CO-123
  - scripts CO-126
- dump command CO-120, CO-275, CO-277
  - described CO-120
  - format TO-56, TO-60
- dumpdates file CO-120, TO-57, TO-61
- dumping files CO-120
- DUPS, scanning with fsck OP-116
- dynamically monitoring CPU activity CO-12

## E

- edactwho command CO-187, CO-351
- EDITOR environment variable CO-173
- edquota command CO-193
- enable\_unique\_core, CPU boot-time parameter CO-291
- encrypting files CO-17

environment variable  
 setting SILOHOST TM-148  
 erase\_pattern, CPU boot-time parameter CO-291  
 erase\_unlink, CPU boot-time parameter CO-292  
 erasing deleted files CO-16  
 errlog CO-333, CO-335  
 error logging, printer CO-136  
 error messages  
 crash dumps OP-145  
 fsck  
 cleanup phase OP-129  
 phase 1B OP-116  
 fsck utility OP-108  
 initialization phase OP-109  
 phase 1 OP-113  
 phase 2 OP-117  
 phase 3 OP-122  
 phase 4 OP-123  
 phase 5 OP-127  
 phase 6 OP-128  
 general tape system TM-171, TO-97  
 line printer system OP-149  
 lpc utility OP-150  
 lpd OP-151  
 lpmv utility OP-151  
 lpq utility OP-151  
 lpr utility OP-153  
 lprm utility OP-154  
 opreq utility TM-182, TO-108  
 sysgen CO-327  
 tape TM-169, TO-95  
 tape system CO-181  
 tpconfig utility TM-180, TO-106  
 /etc/activities CO-350  
 /etc/actwho CO-351  
 /etc/disktab CO-67, CO-106, CO-111, CO-357  
 /etc/fstab CO-122, CO-361  
 /etc/group CO-185, CO-368  
 /etc/hosts CO-369  
 /etc/login CO-2  
 /etc/motd CO-372  
 /etc/nologin CO-373  
 /etc/op.access CO-376  
 /etc/passwd CO-5, CO-379  
 /etc/phones CO-381  
 /etc/printcap CO-371  
 /etc/pwrestrict CO-386  
 /etc/rc.local CO-194, CO-388  
 /etc/remote CO-390  
 /etc/stripecap CO-394  
 /etc/syslog.conf CO-396  
 /etc/termcap CO-398  
 /etc/tty CO-400  
 example of /usr/lib/tape/silodrive TM-150  
 execution priorities OP-29  
 .exrc CO-165, CO-166

## F

faillogon command CO-253, CO-257  
 faillogpr command CO-256  
 failure  
 device messages OP-155  
 disk and machine OP-156  
 failure\_log CO-19  
 failure\_log files CO-254  
 faults, syspic window CO-19  
 fg command OP-162, OP-167  
 field command TO-9  
 field-comment command TO-26, TO-38, TO-40, TO-45  
 fields CO-131  
 field-vsn command TO-26, TO-38, TO-40, TO-46  
 file  
 /ioconfig CO-33, CO-60, CO-62  
 /usr/lib/sendmail.cf, syntax CO-229  
 /.crontab CO-160  
 access-template CO-247  
 activities CO-186  
 avail.notes CO-250  
 backing up CO-120  
 contactcap CO-320  
 crontab CO-159, CO-160, CO-249  
 .cshrc CO-165, CO-166  
 /etc/activities CO-186, CO-350  
 /etc/actwho CO-187, CO-351  
 /etc/disktab CO-36, CO-67, CO-105, CO-106, CO-357  
 /etc/dumpdates CO-120  
 /etc/fstab CO-94, CO-100, CO-122, CO-194, CO-195,  
 CO-361  
 /etc/ftputers CO-56  
 /etc/gettytab CO-40, CO-53, CO-363  
 /etc/group CO-161, CO-172, CO-173, CO-177,  
 CO-274, CO-282, CO-368  
 sample entry CO-282  
 /etc/hosts CO-138, CO-369  
 /etc/hosts.equiv CO-139, CO-141  
 /etc/motd CO-372  
 /etc/nologin CO-373  
 /etc/nurc CO-167, CO-374  
 /etc/op.access CO-277, CO-376  
 /etc/passwd CO-161, CO-163, CO-182, CO-379  
 /etc/phones CO-56, CO-381  
 /etc/printcap OP-38, CO-130, CO-131, CO-189,  
 CO-382  
 /etc/pwrestrict CO-164, CO-175, CO-176, CO-386  
 /etc/rc CO-263  
 /etc/rc.local CO-253, CO-388  
 /etc/rc.std CO-260  
 /etc/remote CO-57, CO-390  
 /etc/stripecap CO-394  
 /etc/syslog.conf CO-258, CO-260, CO-285, CO-396  
 /etc/termcap CO-54, CO-398  
 /etc/tty CO-38, CO-44, CO-400

- /etc/uidcount CO-176
- .exrc CO-166
- .forward CO-209
- fstab CO-122
- hosts.equiv CO-139
- /ioconfig CO-85
- L.cmds CO-159
- L.sys CO-151, CO-154, CO-155
- L-devices CO-144
- L-dialcodes CO-156
- .login CO-166
- .logout CO-166
- /mnt/os CO-315
- /mnt/bootcmd.local CO-290
- /mnt/errlog CO-333
- /mnt/os/bootcmd CO-288
- /mnt/os/bootcmd.local CO-116, CO-288
- op.access CO-277
- password CO-163
- printcap CO-59, CO-61, CO-62, CO-130, CO-136, CO-138
- quotas CO-193
- rc CO-194
- rc.local CO-190, CO-195
- restoring CO-120
- /sys/GENERIC/sysgen/swap.h CO-314
- /sys/sysgen CO-307
- /sys/sysgen/pseudo\_devices CO-311
- /sys/sysgen/REL\_C2 CO-308
- termcap CO-42
- /usr/local/man CO-268
- USERFILE CO-157, CO-157-CO-158
- /usr CO-90, CO-100
  - /adm/tp-acct CO-399
  - /lib CO-133
  - /lib/contactcap CO-320
  - /lib/uucp CO-148
  - /lib/uucp/L.cmds CO-159
  - /lib/uucp/L.sys CO-151
  - /lib/uucp/L-devices CO-144
  - /lib/uucp/L-dialcodes CO-156
  - /lib/whatis CO-269
  - /local/man CO-268
  - /skel CO-165
  - /spool/convxlpd CO-138
  - /spool/mail
  - /spool/contact CO-326
  - /spool/notes/.utilities/avail.notes CO-250
  - /spool/notes/.utilities CO-247
    - /uucp CO-146
    - /uucppublic CO-146, CO-147
- /usr/acct CO-348
- /usr/adm
  - /tp-acct CO-184
  - /acct CO-184
  - /bill-acct CO-184, CO-188
  - /bill-errs CO-184, CO-188
  - /lpd-acct CO-184, CO-188
  - /tp-acct CO-188
  - /wtmp CO-184
- /usr/adm/acct OP-56
- /usr/adm/bill-acct OP-56, OP-66, CO-354
- /usr/adm/bill-errs OP-56, OP-61
- /usr/adm/diskuse CO-359
- /usr/adm/failure\_log CO-19, CO-256, CO-360
- /usr/adm/lpd-acct CO-371
- /usr/adm/messages CO-260
- /usr/adm/opreq-acct OP-56
- /usr/adm/shutdownlog CO-392
- /usr/adm/stat/\* CO-393
- /usr/adm/tp-acct OP-56, OP-69
- /usr/adm/tp-errs OP-61
- /usr/adm/wtmp OP-56, OP-61, OP-66, CO-402
- /usr/lib/aliases OP-87, CO-204, CO-353
  - configuration, options for CO-209
  - format CO-204
- /usr/lib/aliases.dir OP-87
- /usr/lib/aliases.pag OP-87, CO-204
- /usr/lib/aliases.dir CO-204
- /usr/lib/crontab OP-34, CO-254, CO-262, CO-355
- /usr/lib/sendmail.cf
  - procedure to modify CO-230, CO-239
  - syntax CO-211
- /usr/lib/uucp CO-3
- /usr/lib/uucp/L.cmds CO-338
- /usr/lib/uucp/L.sys CO-339
- /usr/lib/uucp/L-devices CO-336
- /usr/lib/uucp/L-dialcodes CO-337
- /usr/lib/uucp/USERFILE CO-3, CO-347
- /usr/spool/convex/avail.conf CO-261
- /usr/spool/convex/availlog CO-261
- /usr/spool/convex/reboot\_log CO-261
- /usr/spool/lpd OP-38
- /usr/spool/mail CO-18
- /usr/spool/mqueue CO-18, CO-203
- /usr/spool/mqueue directory OP-82
- /usr/spool/mqueue/syslog OP-88
- /usr/spool/uucp/LOGFILE CO-335, CO-341
- /usr/spool/uucp/SYSLOG CO-346
- /usr/tmp CO-15
- /usr/ucb/mail CO-18
- /usr/ucb/quota CO-25
- file/etc/fstab CO-122
- file access CO-6, CO-10
- file access permissions
  - setting default TM-104
- file contents
  - protecting CO-16
- file system
  - (root) CO-69, CO-90
  - /bin CO-70
  - /dev CO-70
  - /etc CO-70
  - /mnt CO-70, CO-90

- /tmp CO-69, CO-90
- /usr CO-70, CO-90, CO-100
- Caution OP-97
- checking OP-93
- checking connectivity OP-102
- checking information OP-98–OP-102
- concepts CO-69
- data blocks OP-94
- fragments OP-97
- hierarchical tree CO-69
  - disk configuration diagram CO-88
- inconsistency causes OP-97
- inodes OP-94, OP-95
- striped OP-51
- summary information OP-94
- superblock OP-94
- file systems
  - ConvexOS CO-69
  - creating new CO-106, CO-111
- file-access logging CO-253
  - stopping CO-257
- files
  - /etc/rc.std TM-62
  - /usr/lib/tape/config.db TM-67
  - /usr/lib/tape/silodrivelist TM-150
  - backing up TO-54
  - changing access with chmod command CO-10
  - config.db TM-67
  - .contact OP-162, OP-166
  - creating necessary to UUCP CO-146
  - default user CO-165
  - defaults constants file CO-168
  - /dev/rmt8 TO-56, TO-61
  - device CO-30
  - encrypting CO-17
  - erasing deleted CO-16
  - /etc/dumpdates TO-57, TO-61
  - /etc/group TO-56, TO-61
  - failure\_log CO-254
  - .opreqrc TO-12
  - performing backups TO-53
  - protecting access to CO-6
  - rc.std TM-62
  - restoring TO-53–63
  - restoring from labeled tape TO-66–TO-68
  - restoring from unlabeled tape TO-63–TO-65
  - restoring interactively TO-69
  - security CO-1
  - setting up accounting CO-185
  - special device CO-21
  - transferring
    - between printer queues OP-38
    - to the spooling area OP-38
  - user CO-161
  - /usr/lib/opreq/.opreqrc TO-20
- filters
  - accounting OP-61
  - creating CO-140
  - output CO-134
  - umask CO-8
- find command CO-178
- finding version numbers OP-161
- foreground (fg command) OP-162
- formatting online man pages
  - individually CO-269
  - preformatting CO-269
- .forward file CO-209
- fp\_default\_mode\_issue, CPU boot-time parameter CO-292
- fragment OP-97, CO-66
  - size CO-66, CO-83, CO-96
- free block checking OP-98
- free disk space, monitoring CO-23
- fsck OP-98–OP-122
  - checking cylinder groups OP-127
  - checking path names OP-117
  - checking reference counts OP-123
  - cleaning up OP-129
  - command OP-103, OP-105
  - connectivity checking OP-102, OP-122
  - error messages OP-108, OP-123
    - cleanup phase OP-129
    - phase 1 OP-113
    - phase 1B OP-116
    - phase 2 OP-117
    - phase 3 OP-122
    - phase 5 OP-127
    - phase 6 OP-128
  - error messages, initialization phase OP-109
  - format OP-103
  - free block checking OP-98
  - initialization phase OP-109
- inode
  - checking OP-99
  - data size checking OP-101
  - link checking OP-100
  - related data checking OP-101
- phases OP-105
- running OP-103–OP-106
- salvaging cylinder groups OP-128
- sample session OP-105
- scanning for DUPs OP-116
- superblock checking OP-98
- fsck utility CO-95, CO-114
- fstab file CO-122, CO-361
  - and quotas CO-194

---

**G**

- gateway, CPU boot-time parameter CO-292
- genbyact.awk script OP-61
- genbygrp.aw script OP-61
- genbygrpact.aw script OP-61

- generating automatic accounting reports OP-58
- generating system images, see system generation
- genrest command CO-175
- getnewbuf\_goal, CPU boot-time parameter CO-293
- getst OP-147
- getst command OP-53, OP-147, OP-157, CO-75, CO-88
- getty process CO-363, CO-400
- gettytab file CO-363
  - and modems CO-53
  - and terminals CO-40
- granting operator-class privileges CO-273
- grep command CO-150
- group ID CO-177
- groups CO-177
  - file CO-368, TO-56, TO-61

---

## H

- hardware dump OP-133
- hardware, setting up CO-46
- help command TM-73
- help command, line printer system OP-40
- history log files CO-261
- host name CO-369
- hot spare OP-156, CO-76
  - adding CO-112
  - partitions CO-112
  - reclaiming space OP-54
  - reclaiming status OP-54
  - status OP-53
  - tracking status OP-53
- HSP driver CO-27

---

## I

- I/O
  - buffered CO-16
  - monitoring network CO-14
- ibmdaemon TM-6
- IDC CO-33
- IDC drivers CO-27
- idtoname utility OP-76
- idx\* directories CO-272
- image
  - saving image of tape system configuration TM-72
- inetd daemon TO-1
- Info opreq message type TO-15
- information
  - on path names OP-xvi
  - online OP-xvi
  - supplemental OP-xix
  - tape system TM-74
- init process CO-400
- inodes OP-95, CO-98
  - checking blocks and sizes OP-113
  - checking data associated with OP-101

- checking data size OP-101
- checking links OP-100
- checking number available CO-99
- checking the state OP-99
- optimum number CO-98
- interface CO-25
- Internet CO-369
- /ioconfig entries TM-95
- ioconfig file CO-21–CO-22, CO-84–CO-85
  - and disks CO-35
  - and HSP controllers CO-29
  - and HSP driver CO-27
  - and I/O controller CO-26
  - and IDC controllers CO-28
  - and IDC driver CO-27
  - and IOP controllers CO-28
  - and plotters CO-62
  - and printers CO-60
  - and terminals CO-37
  - and VIOP controllers CO-28
- bus description CO-25, CO-28
- CCU description CO-26
- controller designations CO-403
- controller types CO-26
- device designations CO-403
- device numbering CO-33
- driver designations CO-403
- example CO-22
- ipforwarding, CPU boot-time parameter CO-293
- ispendedirects, CPU boot-time parameter CO-293

---

## K

- kernel boot-time parameters CO-287–CO-303
- kill command CO-260, CO-285

---

## L

- L.cmds CO-159
- L.cmds file CO-159, CO-338
- L.sys CO-151
- L.sys file CO-151, CO-213, CO-339
  - escape sequences CO-154
  - keywords for send strings CO-155
- label daemons TM-6
- label permissions
  - specifying who can bypass TM-126
- label restrictions, bypassing TO-51
- label tapes
  - displaying valid types TM-79
- label types
  - adding TM-105
  - deleting TM-105, TM-108
  - viewing current TM-106
- labeled tapes
  - restricting use TM-133

- labeled-tape file access permissions
  - setting default TM-104
- labels
  - displaying information with `tpconfig` TM-79
- lable types
  - adding new TM-107
  - changing name of currently defined TM-109
- lastcomm command OP-60
- lastcomm utility OP-60
- ld utility CO-15
- L-devices file CO-144, CO-336
- L-dialcodes CO-156
- L-dialcodes file CO-156, CO-337
- limits, monitoring current CO-25
- line printer system
  - abort OP-40
  - access control CO-141
  - accounting CO-135
  - checking a queue OP-46
  - checking queues OP-46
  - clean OP-40, CO-137
  - controlling access CO-141
  - daemon OP-38, OP-42, OP-43
  - disable OP-40, OP-43
  - disabling a queue OP-43
  - down OP-40
  - enable OP-40, OP-43
  - enabling a queue OP-43
  - error messages OP-149
  - exit OP-40
  - filters CO-134, CO-140
  - filters, creating CO-140
  - help OP-40, OP-42
  - logging errors CO-136
  - managing OP-40–OP-49
  - parallel CO-137
  - printing files in a queue OP-38
  - queues OP-43, OP-44, OP-45
  - queues, checking OP-46
  - queues, moving jobs OP-48
  - queues, removing jobs OP-49
  - quit OP-40
  - redirect OP-40, OP-44
  - remote CO-138
  - removing jobs from the queue OP-49
  - restart OP-40, OP-43
  - restarting OP-43
  - restarting printer OP-43
  - scheduling downtime OP-45
  - serial CO-136
  - setting up CO-129
  - setting up new CO-136
  - start OP-40, OP-42
  - starting daemon OP-42
  - status OP-40
  - stop OP-40, OP-42
  - stopping daemon OP-42
  - topq OP-40, OP-44
  - undirect OP-40
  - up OP-40
- link*, title bar label TO-14
- load averages CO-6, CO-7
  - monitoring local machines CO-6
  - monitoring remote machines CO-7
- load balancing, disk CO-80
- log files CO-19
  - accounting CO-184
  - activating history CO-261
  - availlog CO-261
  - collection CO-184
  - crash dump OP-134, OP-137, OP-141
  - errlog OP-134, OP-137, OP-141
  - failure\_log CO-252
  - printer CO-136
  - reboot\_log CO-261
  - setting up CO-251
  - syslog.conf file CO-285
  - UUCP CO-26
- log information, printing CO-256
- logging
  - configuration file CO-261-263
  - configuring system message CO-258
  - enable CO-253
  - errors
    - crash dump OP-134, OP-137, OP-141
    - failed file-access attempts CO-19, CO-252
    - failed login attempts CO-20
    - file access failures CO-253
    - messages CO-258
    - printing log information CO-256
    - reboots CO-261
    - sendmail OP-88
    - stop file-access logging CO-257
    - tunable parameters CO-253
    - uptime statistics CO-261
- logging errors
  - printer CO-136
- .login CO-165, CO-166, CO-372, CO-373
- .logout CO-165, CO-166
- logresume, CPU boot-time parameter CO-293
- logsuspend, CPU boot-time parameter CO-294
- lost+found directory OP-102
- lpc command CO-137
- lpc enable command CO-137
- lpc restart command CO-137
- lpc utility OP-40–OP-45
  - commands OP-40
  - error messages OP-150
  - exiting OP-41
  - parameters OP-41
- lpd
  - daemon OP-38
  - directory OP-38
  - lpd.lock OP-38

lpd-acct file CO-184, CO-188, CO-371  
queue CO-136  
lpd command  
error messages OP-151  
lpmv command OP-48  
error messages OP-151  
lpq command OP-47  
error messages OP-151  
lpr command OP-37  
error messages OP-153  
lprm command OP-49  
error messages OP-154  
ls command CO-6, CO-7  
LSM (Library Storage Module) TO-71, TO-79  
LSM (Library Storage Modules) TM-151

---

## M

machine failure OP-156  
mail  
directory CO-18  
mailbox file CO-18  
MAILER-DAEMON CO-207  
mailers  
definition in sendmail.cf file CO-225  
how invoked by sendmail CO-202  
local CO-202, CO-221, CO-227, CO-228  
mailq command OP-84  
messages  
example CO-199  
header formats CO-218  
how routed CO-202  
parts of CO-199  
verifying delivery of CO-242  
protecting files CO-18  
queue OP-78  
force processing of OP-84  
printing OP-84  
priority of messages in OP-83  
queue timeout OP-82  
system security CO-18  
mail queue CO-203  
MAILER-DAEMON CO-207  
mailq OP-84  
mailq command OP-84  
maintaining user accounts CO-161  
major number CO-31  
MAKEDEV command TM-90  
MAKEDEV shell script CO-103  
making notesfiles CO-248  
man command CO-267  
man pages  
/usr  
/local  
/man CO-268  
creating a search database CO-270

creating indexes CO-272  
formatting online CO-268  
individually CO-269  
preformatting CO-269  
indexes CO-272  
organization CO-266  
table of contents CO-270  
manual report generation, accounting OP-60  
mapping disk space CO-66  
max\_swapout, CPU boot-time parameter CO-294,  
CO-300  
max\_user\_processes, CPU boot-time parameter CO-294  
maxregions, CPU boot-time parameter CO-294  
maxusers, CPU boot-time parameter CO-294  
Mb/s, syspic window CO-16  
memory Mb, syspic window CO-17, CO-21  
message of the day CO-372  
messages  
assigning to yourself TO-34  
canceling TO-30  
indicating completion TO-32  
MID, title bar label TO-14  
min\_swapout, CPU boot-time parameter CO-300  
miniroot on, CPU boot-time parameter CO-294  
minor number CO-31  
mkdir command CO-176  
modems  
adding CO-21, CO-45  
adding hardware CO-46  
and UUCP CO-53  
communication parameters CO-47  
configuring connections CO-144  
configuring software CO-53  
dial settings CO-55  
dialing in CO-52, CO-56  
dialing out CO-53  
gettytab file CO-40, CO-53  
ttys file CO-54  
monitoring  
activity dynamically CO-12  
CPU activity CO-10  
CPU use CO-6  
current disk space limits CO-25  
current disk space use CO-25  
dial settings CO-55  
disk use CO-23, CO-24, CO-25  
load averages CO-6, CO-7  
network I/O CO-14  
pending UUCP activity CO-26  
process status CO-8  
processes dynamically CO-19  
quota limits CO-25  
system activity CO-12  
used disk space CO-24  
UUCP  
uuclean CO-26  
UUCP use CO-26

- logfile CO-26
- pending activity CO-26
- uulook CO-26
- uusnap CO-26
- monthly script OP-58
- motd file CO-372
- mount command OP-52, CO-77, CO-113, CO-115
- mount points CO-77
- mount status
  - reporting TM-158, TO-80
- mounting
  - labeled tapes with opreq TO-38
  - tape sets with opreq TO-40
  - unlabeled tapes with opreq TO-48
- Mount-Tape opreq message type TO-15
- mqueue file OP-82, CO-18
- MTD numbers and associated drives TM-85
- multiple-time execution, scheduling OP-34
- multiuser mode CO-115
- mvst command OP-52, OP-148, OP-158

---

## N

- naming conventions
  - disk CO-34, CO-79
  - partition CO-79
  - stripe CO-79
- network I/O, monitoring CO-14
- New opreq message status TO-14
- newaliases command OP-87, CO-210
- newfs command CO-105, CO-106, CO-109
  - creating file systems with CO-106
  - format CO-106
- newst command OP-54, CO-74, CO-92, CO-109, CO-394
  - example CO-112
  - format CO-111
  - options CO-111
- nfsaccess command CO-248
- nfs\_portmon, CPU boot-time parameter CO-295
- nice command OP-30
- nice values OP-29, OP-30
  - changing OP-30
  - specifying OP-30
- nodes
  - adding TM-84
  - deleting from the tape system TM-94
- /nologin CO-373
- notational conventions OP-xvii
- Notes
  - all initialization errors are fatal OP-109
  - backup frequency recommendations CO-122
  - default user files CO-165
  - df command output CO-87
  - /etc/fstab's *freq* field CO-102
  - file system dumping CO-95

- fsck utility OP-98
- having enough inodes CO-98
- make sure uucp file exists CO-150
- minimum fragment sizes on redundant stripes CO-96
- mount point directories CO-78
- mount points must have access mode 777 CO-78
- mounting/unmounting root file system CO-77
- op logs problems to stderr output CO-285
- raising nice value priority OP-30
- removing user accounts CO-178
- root file system cannot be mounted CO-77
- rules for regular expressions, /etc/op.access file CO-278
  - some file systems will not unmount OP-103
- unmount redundant stripe before using mvst OP-52
- unmounted file systems do not appear CO-87
  - /usr/spool/uucp file access permissions CO-149
- notesfile
  - director CO-246
  - director, setting CO-248
  - public CO-250
- notesfile system
  - access, default CO-246
  - access, setting CO-247
  - controlling CO-246
  - creating CO-247
  - creating notesfiles CO-247
  - described CO-246
  - making notesfiles CO-248
  - networked CO-248, CO-249
  - setting up CO-245
- nstbuf, CPU boot-time parameter CO-295
- nu command CO-169, CO-172
- nu utility CO-167, CO-170
  - example session CO-170
- number\_ptys, CPU boot-time parameter CO-295
- number\_ta\_iop\_wndw, CPU boot-time parameter CO-295
- number\_tty\_controllers, CPU boot-time parameter CO-295
- /nurc CO-374

---

## O

- one-time execution, scheduling OP-32
- online man pages, formatting CO-268
- op
  - command OP-1, OP-3
  - command options CO-279
  - default definition CO-279
  - default line CO-282
  - description CO-274
  - help facility, using OP-3
  - interface CO-274
  - literal arguments CO-277
  - security issues CO-276

- task OP-4
- utility CO-273, CO-274, CO-376
- variable arguments CO-277
- op command CO-284
- op.access file CO-274, CO-276–CO-286, CO-376
- creating CO-282
- defaults for command options CO-279
- example CO-284
- planning CO-277
- operator interface facility, see op
- operator interface system, see op
- opreq TO-3
  - error messages TM-182
- opreq utility TO-3
  - assign a message to yourself TO-34
  - Auto-Vol-Rec messages TO-36
  - AVR TO-36
  - cancel a message TO-30
  - change tapes in a tape set TO-45
  - commands TO-6
  - complete a message TO-32
  - configuring window defaults TO-20
  - disabling a tape drive TO-24
  - display
    - additional information TO-9
    - available drives TO-8
    - comments sent by a tape user TO-27
    - VSNs in a tape set TO-28
  - enter commands TO-7
  - error messages TO-108
  - help TO-6
  - Info messages TO-36
  - messages
    - displaying according to type TO-18
  - mount requests for labeled tapes TO-35
  - mount requests for unlabeled tapes TO-48
  - opreq-acct file OP-56
  - refresh screen TO-8
  - screen movement commands TO-5
  - single-volume, labeled-tape mount requests TO-38
  - tape set requests TO-40
  - unmount requests TO-50
- opreq window TO-4
  - close TO-10
  - command line TO-5
  - configure title bar TO-12
  - configuring defaults TO-20
  - displaying messages according to
    - status TO-16
    - type TO-18
  - messages area TO-5
  - move from one to another TO-10
  - open TO-10
  - title bar TO-4
- opreq\_daemon TM-5, TO-1
- opreq-acct OP-56
- .opreqrc file TO-20

- example of file contents TM-138, TO-22
- two-screen display example TM-139, TO-23
- .opreqrc file in your current directory TO-20
- options
  - tpconfig TM-75
- ordering documents OP-xxi
- osclean command OP-134, OP-137, OP-141
- output filters CO-134

---

## P

- pac command OP-60, OP-61, OP-71
- paging CO-15
- paging, syspic window CO-15
- parameters
  - CPU boot-time, *table* CO-290
  - customizing kernel boot-time CO-287–CO-303
  - STREAMS tunable, *table* CO-303
  - VIOP boot-time, *table* CO-302
- parity file systems CO-73
- partitions CO-65, CO-90
  - hot spare CO-112
  - naming conventions CO-79
  - striped CO-72, CO-108
  - removing OP-52
  - swap CO-312
- passive system CO-144, CO-150, CO-151, CO-156
- passwd command CO-176
- password
  - aging CO-4, CO-163
  - file CO-163, CO-379
  - length/character requirements CO-163
  - pwrestrict CO-170
  - restrictions CO-4, CO-163, CO-386
  - superuser CO-15
- path cache, syspic window CO-18
- path name, finding a program's OP-160
- per-CPU usage, syspic window CO-21
- pgout\_macrss, CPU boot-time parameter CO-296
- pgout\_maxscan, CPU boot-time parameter CO-296
- pgoutgoal\_rssdiv, CPU boot-time parameter CO-296
- phase 4 OP-123
- /phones CO-381
- ping command OP-151
- pline printer system
  - help OP-40
- plotter, adding CO-62
- port status
  - reporting TM-159, TO-81
- portmap daemon TO-1
- Postmaster CO-207
- preen
  - command OP-103, OP-107, CO-115
  - utility CO-114, CO-362
- preen command OP-148, CO-316
- preventing misuse of system CO-15

- printcap file CO-59, CO-61, CO-130, CO-138, CO-382
  - and accounting CO-189
  - and line printer daemon OP-38
  - and remote printer CO-138
  - and serial printer CO-136
  - fields CO-131
- printer daemon CO-137
- printer queues
  - checking OP-46
  - disable OP-43, OP-45
  - displaying OP-38
  - enable OP-43
  - manipulate jobs OP-44
  - moving jobs OP-48
  - redirect OP-44
  - removing jobs OP-49
  - restarting OP-43
- printers
  - accounting CO-371
  - adding CO-59
  - adding serial CO-59
  - adding to PRC controller CO-60
  - errors, accounting system CO-181
  - summarizing use data OP-70
  - use, accounting system CO-181
- printers, see line printer system
- printing log information CO-256
- priorities, changing process OP-29
- problem reporting
  - via a network CO-319
  - via UUCP CO-319
- problems
  - priority of OP-168
  - reporting OP-159
- Process ID (PID) CO-27
- processes
  - changing priorities OP-29, OP-30
  - controlling OP-29–OP-35
  - execution priority OP-29, OP-32
  - nice values OP-29
  - process status CO-18
    - monitoring CO-8
  - scheduling OP-32–OP-35
  - syspic window CO-18
  - termination data, summarizing OP-62
- program version number, finding OP-161
- protecting
  - file contents CO-16
  - mail files CO-18
  - the system, using log files CO-19
- ps command CO-8–CO-9
- ps commmand OP-30
- pseudo\_devices file CO-311
- pseudoteletype devices CO-295
- pseudoterminals, configuring CO-43
- public
  - directories CO-12

- notesfiles CO-250
- putst utility CO-394
- /pwrestrict CO-386

---

## Q

- qst command OP-54, OP-147, OP-157
- queues
  - lpd CO-136
  - printer OP-43, OP-44, OP-45, OP-46, OP-48, OP-49
- quota command CO-23, CO-25
- quota limits, monitoring CO-25
- quota utility CO-25
- quotacheck command CO-194
- quotaon command CO-194
- quotas CO-115
  - file CO-193
  - hard limit CO-191, CO-193
  - on networks CO-195
  - soft limit CO-191, CO-193
  - start CO-194
  - time limit CO-191, CO-193

---

## R

- raw device CO-30, CO-79, CO-103
- rc file
  - and logging history CO-263
  - and quotas CO-194
- rc.local file CO-388
  - and accounting CO-190
  - and logging CO-253
  - and quotas CO-195
- rc.std file
  - and line printer daemon OP-38
  - and logging CO-260
  - and opreq\_daemon TM-62
  - and syslog daemon CO-260
  - and tpd daemon TM-62
- rdump TO-56, TO-61
- rdump command CO-120, TO-56, TO-61
- Ready opreq message status TO-14
- reboot command CO-117
- reboot\_log CO-261
- recovery from system crashes OP-147–OP-148
- redirecting queues, printer OP-44
- redundant striping CO-73
  - hot spares CO-76
  - mirroring CO-73
  - optimum stripe width CO-81
  - parity CO-74
  - partitions CO-73
  - using the newst command with CO-110
- reference count checks, fsck utility OP-123
- /remote CO-390
- remote printer CO-138

remote sites, crontab script for polling CO-159

removing

files from printer queue OP-38

old UUCP files CO-27

user accounts CO-178

renice command OP-31

Replace-Tape opreq message type TO-15

replacing TM-129

access drive list TM-115

allocate drive list TM-122

bypass label list TM-129

replacing stripe partitions OP-52

replacing tapes with opreq TO-45

reporting

ACS (Automated Cartridge System) status TO-76

ACS status TM-154

CAP (Control Access Port) status TO-77

CAP status TM-155

LSM (Library Storage Module) status TO-79

LSM status TM-157

mount and tape drive status TO-80

mount status TM-158

port status TM-159, TO-81

request status TM-160, TO-82

server status TM-161, TO-83

tape drive status TM-156, TO-78

tape drives status TM-158

volume status TM-162, TO-84

reporting problems OP-159

reports, accounting, see accounting reports

request status, reporting TM-160, TO-82

resetting

control status TM-97

resetting time out limits TM-97

resource monitoring CO-5

responding to

requests to change existing volumes TO-45

requests to mount and label tape sets TO-40

requests to mount existing volumes TO-45

single-volume requests TO-38

unmount requests TO-50

restore command TO-64, TO-67

interactive mode TO-69

restoring files CO-120, TO-54–TO-63

interactively TO-69

restoring files from labeled tape TO-66–TO-68

restoring files from unlabeled tape TO-63–TO-65

restricting use

to labeled tapes only TM-133

to secure volume headers only TM-133

ring, title bar label TO-14

rmst command OP-54

RO (read only) opreq ring status TO-14

root directory CO-15, CO-69, CO-90

rrestore command TO-64, TO-67, TO-68

ruptime command CO-7

ruptime utility CO-6

RW (read and write) opreq ring status TO-14

---

## S

sa command OP-62

sabyact.aw script OP-60

sabygrp.awk script OP-60

satcker/loader

adding to your system TM-144

scheduling

downtime OP-45

future one-time execution OP-32

multiple-time executions OP-34

processes OP-32

scripts

daily OP-58

monthly OP-58

weekly OP-58

search, creating database CO-270

secure volume headers

restricting use TM-133

security

adding extra measures TM-133

autologout command CO-2

considerations CO-1, CO-276

password restrictions CO-15

preventing misuse CO-15

protecting

access to files CO-6

file contents CO-16

login access CO-4

mail files CO-18

physical access CO-2

the system using log files CO-19

UUCP or dialin access CO-3

public directories CO-12

sticky bit CO-12, CO-15

superuser password CO-15

tape system TM-133

seestat utility CO-393

select-cancel command TO-26

select-cancelcommand TM-140

select-done command TM-140, TO-26

select-work command TM-140

sendmail

aliases file CO-353

configuration file

class definition CO-212

classes C and F CO-212

defined CO-213

freezing OP-80

header formats CO-218

macro definition CO-213

macros, predefined CO-214

macros, required CO-215

mail relay hosts, defining CO-234–CO-237

- mailer definition CO-225
- mailer flags CO-227
- message precedence CO-217
- modifying CO-230–CO-239
- option definition CO-216
- procedure to modify CO-230
- trusted users CO-217
- when to refreeze OP-80
- daemon
  - killing CO-238
- daemon, killing OP-80
- debugging OP-91, CO-240
- error handling CO-203
- header formats CO-218
- load limiting options OP-85
- log file format OP-90
- log levels OP-88
- mailers CO-225
- messages
  - how routed CO-198
- process name as seen by ps OP-78
- rewriting rules CO-219-222
- rule sets CO-222–225
- starting OP-78, OP-79
  - with a new configuration file OP-81
- testing CO-240–CO-244
  - address rewriting CO-240
  - direct mailing CO-243
  - verifying addresses CO-242
  - verifying mail delivery CO-242
- utility CO-353
- sendmail command OP-79–OP-87, CO-240
- sendmail log OP-88
- sendmsg\_access\_rights, CPU boot-time parameter CO-296
- serial printer CO-136
- server status
  - reporting TO-83
- server status, reporting TM-161
- Service Processor Unit (SPU) CO-21, CO-22
- set list command CO-130
- set queueing enabled command TM-141
- setenv SILOHOST TM-148, TO-72
- setting
  - default drive type TM-100
  - default flags TM-102
  - default labeled-tape file access permissions TM-104
  - default tape density TM-101
  - default tape speed TM-103
  - SILOHOST TM-148
- setting up
  - accounting files CO-185
  - accounting system CO-181
  - log files CO-251
  - man pages CO-265
  - notesfile system CO-245
  - quotas CO-191
  - the disk system CO-65
  - the line printer system CO-129
  - the tape system TM-65
  - user accounts CO-162
  - UUCP connection CO-143
- setting, local options for contact utility CO-322
- sgid bits CO-14
- shutdown command CO-113, CO-290, CO-315
  - /shutdownlog CO-392
- silodismount command TM-148, TM-168, TO-71, TO-90
- silodrivelist file TM-150
- siloeject command TM-148, TO-71, TO-88
- siloenter command TM-148, TM-163, TO-71, TO-85
- Silo-Enter opreq message type TO-15
- SILOHOST environment variable, setting TM-148, TO-72
- silomount command TM-148, TO-71, TO-89
- siloquery command TM-148
- siloquery utility TO-71
  - table of commands TM-152
- siloquery utility commands
  - acs TO-74
  - cap TO-74
  - drive TO-74
  - lsm TO-74
  - mount TO-75
  - port TO-75
  - request TO-75
  - server TO-75
  - volume TO-75
- single-volume requests, responding to TO-38
- SMTP commands CO-243
- sockets, used to handle printer requests OP-38
- space
  - monitoring free disk CO-23
  - monitoring used disk CO-24
- spares, hot CO-76
- special device files
  - block CO-30
  - character CO-30
- specifying nice values OP-30
- SPU CO-21
- spu
  - command CO-84
  - files CO-84, CO-100
- spu command CO-22
- spu -r command CO-289
- spu -w command CO-290
- stacker/loader
  - deleting from your system TM-146
  - showing daemon information TM-145
- startup files CO-165
- stat utility CO-393
  - /stat/\* CO-393
- status, title bar label TO-14
- sticky bit CO-12, CO-15
- stiping

- redundant partitions CO-73
- StorageTek 4400 Automated Cartridge System (ACS),  
refer to ACS
- str\_ctl\_sz CO-303
- str\_dblk\_0 CO-303
- str\_dblk\_1024 CO-303
- str\_dblk\_128 CO-303
- str\_dblk\_16 CO-303
- str\_dblk\_2048 CO-303
- str\_dblk\_256 CO-303
- str\_dblk\_4 CO-303
- str\_dblk\_4096 CO-303
- str\_dblk\_512 CO-303
- str\_dblk\_64 CO-303
- str\_lo\_pct CO-303
- str\_med\_pct CO-303
- str\_msg\_sz CO-303
- str\_n\_event CO-303
- str\_n\_mblk CO-303
- str\_n\_muxlink CO-303
- str\_n\_push CO-303
- str\_n\_queue CO-303
- str\_n\_stream CO-303
- str\_n\_tevent CO-303
- STREAMS tunable parameters CO-303
- strip command CO-14
- stripe
  - naming conventions CO-79
  - sections CO-75
  - stripe\_devices boot-time parameter CO-296
  - striped partitions CO-72
- /stripecap CO-394
- striped file systems, maintaining OP-51-OP-54
- striping CO-72
  - disks CO-80
- subnetsarelocal, CPU boot-time parameter CO-297
- suggestions for documentation or support OP-169
- suid bits CO-14
- suid\_shell\_script, CPU boot-time parameter CO-297
- summarizing data
  - disk use OP-73
  - login and logout OP-66
  - printer use OP-70
  - process termination
    - by command execution sequence OP-64
    - by group and activity combinations OP-62
  - tape use OP-68
  - using the pac utility OP-71
- superblock OP-94
  - checking OP-98
- superuser OP-2, CO-162
  - operator-class information CO-274
- swap device CO-328
- swap partitions CO-312
- swap space CO-71, CO-93
- swap\_nicehg, CPU boot-time parameter CO-301
- swap\_pagerate, CPU boot-time parameter CO-300

- swap\_partswpchg, CPU boot-time parameter CO-301
- swap\_restimechg, CPU boot-time parameter CO-301
- swap\_rsschg, CPU boot-time parameter CO-301
- swapvmmunix.c file CO-314
- syntax
  - tpconfig TM-75
- /sys/sysgen/controllers CO-327
- /sys/sysgen/units CO-327
- sys\_mask, CPU boot-time parameter CO-297
- sysgen, see system generation
- syslog CO-346
  - configuration file CO-396
  - daemon CO-285
    - starting CO-260
- syslog.conf file CO-20, CO-258, CO-260, CO-396
- syslogd process CO-285
- sysname CO-331
- syspic command CO-6, CO-12, CO-19-CO-22
  - described CO-12
  - dynamically monitoring processes CO-6
- syspic utility CO-90
- syspic window
  - buffered I/O CO-16
  - CCU busy CO-16
  - CPU usage CO-18, CO-21
  - example CO-13, CO-20
  - faults CO-19
  - memory Mb CO-17, CO-21
  - network I/O CO-14
  - paging CO-15
  - path cache CO-18
  - per-CPU usage CO-21
  - processes CO-18
  - tape, Mb/s CO-16
  - TTY totals CO-17
- syspic, example window CO-90
- system
  - preventing misuse CO-15
  - protecting CO-19
  - security CO-1
- system calls (that can generate log messages)
  - CO-17-CO-19
- system configuration file CO-328
- system crash recovery OP-147
- system files CO-333
- system generation CO-305
  - bootable system-image files CO-315
  - config line CO-307
  - configuration file CO-306, CO-308, CO-310, CO-312
  - configuration file grammar CO-317
  - configuration parameters CO-306, CO-309
  - described CO-306
  - directories CO-313
  - directory CO-307
  - error messages CO-327
  - generating system CO-313
  - lexical conventions CO-318

- parameters CO-310
- pseudodevices CO-311
- system parameters CO-306
- utility CO-327
- system message, configuring logging CO-258

---

## T

- ta\_force\_EOF\_on\_close, CPU boot-time parameter CO-297
- TAC OP-xx, OP-149, OP-159, CO-319, CO-322, CO-327
  - sending crash dump tapes OP-144
- tape
  - allocations and deallocations CO-181
  - error messages CO-181
  - restoring files from TO-63
  - summarizing use data OP-68
  - tape drives, crash dump to local OP-133
  - tape.awk script OP-60, OP-68
- tape default density, setting TM-101
- tape devices
  - accessing TM-2
  - allocating TM-3
  - attributes TM-89, TO-109
  - device files TM-3
  - displaying default information with tpconfig TM-78
- tape drive
  - disabling a problematic TO-24
  - reporting status TO-78, TO-80
- tape drives
  - adding TM-83, TM-84
  - adding many nodes to TM-92
  - deleting from the tape system TM-94
  - disabling with opreq TO-24
  - displaying information with tpconfig TM-80
  - displaying nodes associated with TM-93
  - reporting status TM-156, TM-158
  - specifying who can access TM-112
  - specifying who can allocate TM-119
- tape operators
  - configuring your system for TM-135
- tape speed
  - setting default TM-103
  - unsetting default TM-103
- tape system
  - access drive list, add groups TM-113, TM-115, TM-117, TM-120, TM-122, TM-124, TM-127, TM-129, TM-131
  - access drive list, add users TM-114, TM-116, TM-118, TM-121, TM-123, TM-125, TM-128, TM-130, TM-132
  - accounting files TO-92
  - bypassing ConvexOS TM-167
  - configuration file TM-67
  - daemons that should be running TO-1
  - defaults
    - setting TM-99
    - delete drives TM-74
    - delete nodes TM-94
    - displaying defaults TM-78
    - displaying info on all tape drive configurations TM-80
    - error messages TM-169, TM-171–TM-179, TO-95, TO-97–TO-105
    - messages TO-5
    - opreq TO-3
    - securing TM-133
  - tape, syspic window CO-16
  - tapelog file TM-170, TO-96
  - technical assistance OP-xx
  - Technical Assistance Center OP-xx, OP-149, OP-159, CO-319, CO-322, CO-325, CO-327
  - tellcron utility OP-35
  - telnet command CO-244
  - termcap file CO-398
    - and modems CO-54
    - and terminals CO-42
  - terminals
    - adding CO-21, CO-37
    - configuration file, *table* CO-363–CO-365
    - naming conventions CO-38
  - tickadj, CPU boot-time parameter CO-298
  - time out limits
    - resetting TM-97
  - time\_zone, CPU boot-time parameter CO-298
  - time-in*, title bar label TO-14
  - time-out*, title bar label TO-15
  - tip utility CO-381, CO-390
  - title bar labels, *table* TO-14
  - title bar, opreq TO-4
  - TLI CO-33
  - TLI drives
    - adding to the ACS TM-149
    - /tmp CO-15
  - touch command CO-193, CO-253, CO-260
  - tp-acct file OP-56–OP-69, CO-184, CO-188, CO-398, CO-399
  - tpattr command TO-60, TO-67
  - tpconfig
    - command notations TM-68
    - commands TM-73
    - error messages TM-180–TM-181, TO-106–TO-107
    - show drives command TM-173, TM-175, TO-99, TO-100
    - show labels command TM-172, TO-97
    - show nodes command TM-174, TM-175, TO-100, TO-101
    - using TM-67
    - using as a single command TM-69
    - using in batch mode TM-71
    - using interactively TM-70
  - tpconfig add access\_drive command TM-112
  - tpconfig add drive command, options TM-87

tpconfig add label command TM-107  
 tpconfig add node command TM-90  
 tpconfig add node command, options TM-91  
 tpconfig add stacker command TM-144  
 tpconfig command TM-68–TM-82  
 tpconfig commands  
   show all TM-76  
   show de (defaults) TM-78  
   show dr (drives) TM-80  
   show labels TM-79  
   show node TM-82  
 tpconfig del stacker command TM-146  
 tpconfig delete access\_drive command TM-112  
 tpconfig se d dr mt command TM-100  
 tpconfig set access\_drive command TM-112  
 tpconfig show all  
   command output sample TM-77  
 tpconfig show all command  
   example TM-76  
 tpconfig show de command TM-78  
 tpconfig show labels command TM-106  
 tpconfig show stackerdaemon command TM-145  
 tpconfig snapshot command TM-72  
 tpconfig utility TM-65  
 tpd daemon TM-5, TO-1  
 tp-errs file OP-61  
 tplabel command TO-60  
 tpmount command CO-399, TO-51, TO-55, TO-59,  
   TO-63, TO-66  
 tpqueue command TM-175, TM-177, TO-101, TO-103  
 tpunmount TO-65, TO-68  
 tpunmount command CO-399, TO-57, TO-62  
 tr\_nrcs, CPU boot-time parameter CO-298  
 tty totals, syspc window CO-17  
 tty\_iop\_size, CPU boot-time parameter CO-298  
 tty\_pty\_size, CPU boot-time parameter CO-298  
 tty\_viop\_size, CPU boot-time parameter CO-298  
 ttys file CO-38  
   and modems CO-55  
   and printers CO-59  
   and pseudoterminals CO-44  
 tunable parameters for logging CO-253  
 type, title bar label TO-15  
 typographic conventions OP-xvii

## U

UID count CO-176  
 UID, title bar label TO-15  
 umask command CO-8, CO-9, CO-15  
   common values CO-9  
 umount command OP-52, CO-78, CO-114  
 uncontrolling a drive with opreq TO-24  
 unmount requests, responding to TO-50  
 Unmount-Tape opreq message type TO-15  
 unsetting

default tape density TM-101  
 default tape speed TM-103  
 update command CO-114  
 updcksum, CPU boot-time parameter CO-299  
 uptime command CO-6  
 uptime utility CO-6  
 USENET CO-3  
 user accounts  
   removing CO-178  
   setting up CO-162  
   types of CO-162  
 user files, default CO-165  
 USERFILE CO-347, CO-348  
   access control CO-157  
 using this guide OP-xiii  
 /usr/adm/acct CO-348  
 /usr/adm/bill-acct CO-354  
 /usr/adm/diskuse directory CO-359  
 /usr/adm/failure\_log CO-360  
 /usr/adm/log/tapelog TM-169, TM-170, TO-95,  
   TO-96  
 /usr/adm/messages CO-285  
 /usr/adm/opreq-acct TO-93  
 /usr/adm/shutdownlog CO-392  
 /usr/adm/stat directory CO-393  
 /usr/adm/tp-acct CO-398, CO-399, TO-92  
 /usr/adm/wtmp CO-402  
 /usr/include/sys/acct.h CO-348  
 /usr/lib/aliases.pag CO-204  
 /usr/lib/opreq/.opreqr TM-137, TO-20  
 /usr/lib/tape/config.db TM-65, TM-180, TM-181,  
   TO-106, TO-107  
 /usr/lib/uucp CO-3  
 /usr/lib/uucp/L.cmds CO-338  
 /usr/lib/uucp/L.sys CO-339  
 /usr/lib/uucp/L-devices CO-144, CO-336  
 /usr/lib/uucp/L-dialcodes CO-337  
 /usr/lib/uucp/USERFILE CO-347  
 /usr/skel  
   directory CO-165  
 /usr/spool/mail directory CO-18  
 /usr/spool/mqueue CO-18  
 /usr/spool/mqueue directory CO-203  
 /usr/spool/notes/.utilities CO-247  
 /usr/spool/uucp/ERRLOG CO-335  
 /usr/spool/uucp/LOGFILE CO-341  
 /usr/spool/uucp/SYSLOG CO-346  
 utilities, also see commands  
 utilities  
   accounting, miscellaneous OP-75  
   catman CO-268  
   connecttime OP-66  
   connecttime OP-60, OP-61  
   contact CO-319  
   cron CO-27, OP-35  
   crypt CO-17  
   df CO-23

- diskuse OP-60
  - du CO-23
  - faillogpr CO-253
  - file CO-247
  - fsck OP-98-OP-106
  - idtoname OP-76
  - lastcomm OP-60
  - ld CO-15
  - login CO-372, CO-373
  - miscellaneous OP-75
  - nu CO-167, CO-170
  - pac OP-60, OP-71
  - preen OP-103, CO-114, CO-362
  - ps CO-8
  - putst CO-394
  - quota CO-23, CO-25
  - ruptime CO-6, CO-7
  - sa OP-62
  - siloquery TM-152, TO-71
  - sysgen CO-313
  - syspic CO-6, CO-10, CO-90
  - tellcron OP-35
  - tpconfig TM-65
  - uptime CO-6
  - uulook CO-26
  - uusnap CO-26
  - vipw CO-173
  - vpiw CO-178
  - .utilities directory CO-247
  - UUCCP
    - L.cmds file CO-159
  - uucico command CO-157
  - uucico process CO-336, CO-339
  - uuclean cron script CO-27
  - UUCP OP-160
    - access permissions CO-146, CO-147, CO-148
    - active system CO-144, CO-150, CO-151, CO-156, CO-157
    - activity log CO-341
    - command control CO-159
    - creating necessary files CO-146
    - delivering problem reports CO-319
    - delivery CO-324
    - describe modems CO-144
    - described CO-143
    - dialcodes CO-337
    - dialing in CO-45
    - dialing out CO-45
    - dialing sequences CO-339
    - dialout device descriptions CO-336
    - error log CO-335
    - file transfer log CO-346
    - L.dialcodes CO-156
    - L.sys file CO-148-156
    - log file, viewing CO-26
    - monitoring pending activity CO-26
    - over Ethernet CO-143
    - passive system CO-144, CO-150, CO-151, CO-156
    - pathname prefixes CO-347
    - polling remote sites CO-159
    - remote access, controlling CO-150
    - remote clients, setting up CO-150
    - remote commands file CO-338
    - removing old files CO-27
    - security CO-3
    - set dialing prefixes CO-156
    - setup CO-146
      - /usr/lib/uucp CO-3
    - uucp directory CO-148
    - uucppublic directory CO-146
    - uulook command CO-26
    - uulook utility CO-26
    - uusnap command CO-26
    - uux command CO-338
    - uv\_num\_windows, VIOP boot-time parameter CO-302
- 
- ## V
- values
    - changing nice OP-30
    - specifying nice OP-30
  - verify command OP-150
  - vers OP-161
  - version number, finding a program's OP-161
  - VIOP boot-time parameters CO-302
  - viop\_enet\_proc, CPU boot-time parameter CO-299
  - vipw CO-173
    - sample line CO-175
    - utility CO-173, CO-178
  - VISUAL environment variable CO-173
  - vmstat command CO-10
  - volume status reporting TO-84
  - volume status, reporting TM-162
  - volumes
    - responding to requests to change existing TO-45
    - responding to requests to mount existing TO-45
  - VSN, title bar label TO-15
  - vmdaemon command OP-158
    - restarting OP-158
- 
- ## W
- Waiting opreq message status TO-14
  - weekly command CO-277
  - weekly script OP-58
  - whatis database CO-269
  - whence OP-160
  - which OP-160
  - window-open, opreq command TM-138, TO-22
  - Working opreq message status TO-14
    - /wtmp CO-402
  - wtmp file OP-56, OP-61, OP-66, CO-184

---

# X

xdump command CO-120, TO-56, TO-60



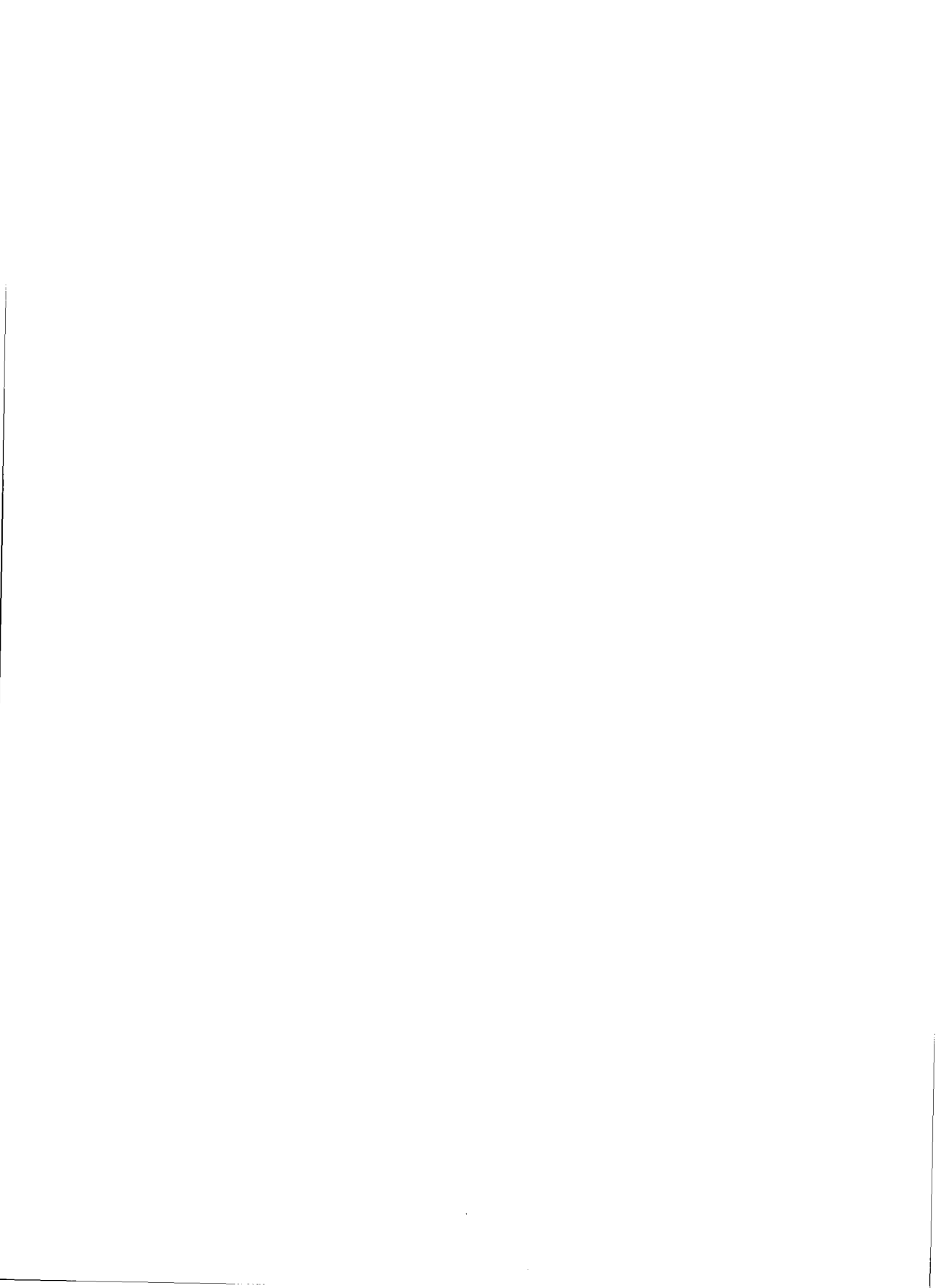









**Order Number**  
**DSW-031**

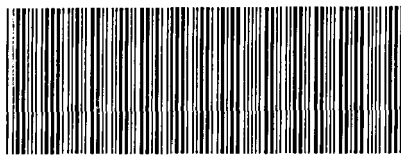

**Document Number**  
**710-011830-003**